

SA's Leading Past Year

Exam Paper Portal



You have Downloaded, yet Another Great Resource to assist you with your Studies 😊

Thank You for Supporting SA Exam Papers

Your Leading Past Year Exam Paper Resource Portal

Visit us @ www.saexampapers.co.za



**SA EXAM
PAPERS**
SA EXAM
PAPERS



Iphondo leMpuma Kapa: Isebe leMfundo
Provinsie van die Oos Kaap: Departement van Onderwys
Porafensie Ya Kapa Botjhabela: Lefapha la Thuto

NATIONAL SENIOR CERTIFICATE

GRADE 12

SEPTEMBER 2024

TECHNICAL SCIENCES P1

MARKS: 150

TIME: 3 hours

This question paper consists of 16 pages, including 3 data sheets.



INSTRUCTIONS AND INFORMATION

1. Answer ALL the questions in the ANSWER BOOK.
2. Start EACH question on a NEW page in the ANSWER BOOK.
3. Number the answers correctly according to the numbering system used in this question paper.
4. You may use a non-programmable calculator.
5. LEAVE ONE line between subsections, e.g. between QUESTION 2.1 and QUESTION 2.2.
6. You are advised to use the attached DATA SHEETS.
7. Show ALL formulae and substitutions in ALL calculations.
8. Round off your final numerical answers to a minimum of TWO decimal places.
9. Give brief motivations, discussions, etc. where required.
10. Write neatly and legibly.

QUESTION 1: MULTIPLE-CHOICE QUESTIONS

Various options are provided as answers to the following questions. Choose the answer and write only the letter (A–D) next to the question numbers (1.1 to 1.10) in the ANSWER BOOK, for example 1.11 D.

- 1.1 Two horizontal forces, F_1 and F_2 , act on the same object, which is on a horizontal surface. The resultant force on the object is zero.



F_1 and F_2 have ...

- A different magnitudes and opposite directions.
B different magnitudes and the same direction.
C the same magnitude but opposite directions.
D the same magnitude and the same direction. (2)
- 1.2 Which ONE of the following statements is CORRECT about inertia?
A Inertia is determined by the mass.
B Inertia is equal to the force applied.
C Inertia is always the same for all objects.
D Inertia is determined by the direction of motion. (2)
- 1.3 Two cars moving at the **same** speed approach each other on a horizontal road. They collide head-on and come to rest after the collision. Ignore the effect of friction.

Which ONE of the following statements is INCORRECT?

- A The two cars have the same mass.
B The total momentum remains constant during the collision.
C The two cars have the same momentum before the collision.
D The two cars have the same kinetic energy before the collision (2)

1.4 Which ONE of the following is the same as the unit Joule?

- A N.m
- B kg.m.s^{-1}
- C N.m^{-1}
- D kg.m.s^{-2} (2)

1.5 Three identical objects **Q**, **R** and **S** are placed underwater at the SAME DEPTH but at different angles as shown in the diagram below.

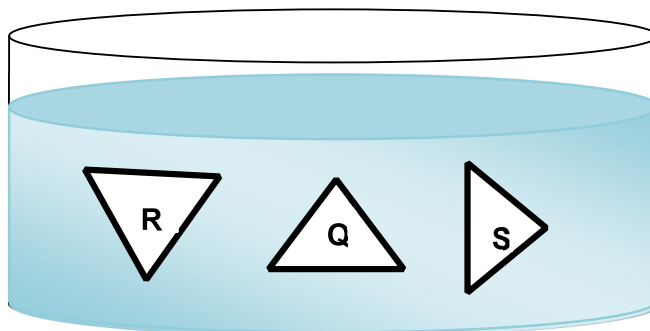

The pressure that the water exerts on the objects is the ...

- A greatest on **R**.
 - B greatest on **Q**.
 - C greatest on **S**.
 - D same on **Q**, **R** and **S**. (2)
- 1.6 A force that changes the shape and size of a body is called ... force.
- A compression
 - B deforming
 - C restoring
 - D tension (2)

- 1.7 When an incident light ray shines on the critical angle of a medium with a high optical density, the ray of light will ...
- A refract towards the normal in the less dense medium.
 - B refract with an angle of 90° between the two media.
 - C refract totally into the optically less dense medium.
 - D reflect totally into the optically denser medium. (2)
- 1.8 If the frequency of a certain electromagnetic wave is X Hertz and its wavelength is equal to Y metres.
- What is the wavelength in metres, if the frequency is doubled?
- A $4Y$
 - B $2Y$
 - C $\frac{Y}{2}$
 - D $\frac{Y}{4}$ (2)
- 1.9 What is the value of the capacitance of a capacitor which has a voltage of 12 V and a charge of 36 C?
- A 3F
 - B 0,3F
 - C 432F
 - D 24F (2)

- 1.10 Consider the circuit diagram below. Bulbs **A**, **B** and **C** are identical with the same resistance.

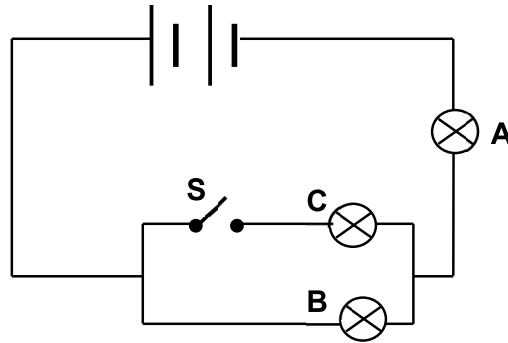

Which ONE of the following options applies to the current of the above circuit?

- A $I_A = I_B$
- B $I_A > I_B$
- C $I_A < I_B$
- D $2I_A = I_B$

(2)
[20]

QUESTION 2 (Start on a new page.)

A person standing at the back of a moving truck, suddenly moves forward when the driver of the truck applies the brakes as shown in the diagram below.

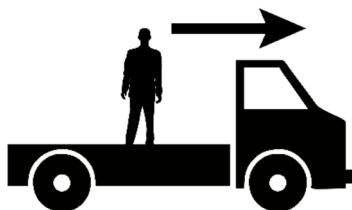

- 2.1 Explain this observation using physics principles. (2)
- 2.2 What is the name of the law used for the explanation in QUESTION 2.1? (1)
- 2.3 Two blocks, **X** and **Y**, with masses of 5 kg and 3 kg respectively, are stationary on a rough, horizontal surface. The blocks are connected by a light, inextensible string. When force **F**, with a magnitude of 25 N and making an angle of 30° with the horizontal, is applied to the 5 kg block, both blocks move to the left.

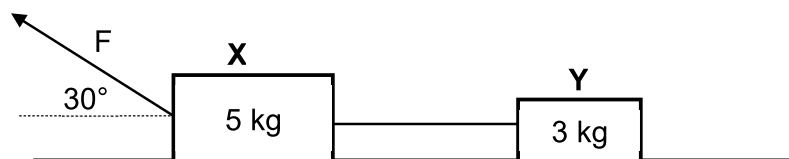

- 2.3.1 State Newton's Second Law of Motion in words. (2)
- 2.3.2 Draw a labelled free body diagram, and identify ALL the forces acting on the 3 kg block. (4)

The coefficient of kinetic friction for blocks **X** and **Y** are 0,2 and 0,1 respectively.

Calculate the:

- 2.3.3 Magnitude of the normal force on block **X** (4)
- 2.3.4 Magnitude of the acceleration of the system of blocks (6)
- 2.3.5 Tension in the string (2)

[21]

QUESTION 3 (Start on a new page.)

In the diagram below an air-rifle pellet of mass 3 g is fired into a stationary block of clay with a mass of 50 g. Before the pellet hits the clay, it is travelling at a velocity of $120 \text{ m}\cdot\text{s}^{-1}$ to the RIGHT. Upon impact, the pellet becomes embedded in the clay and they move forward as a unit. Ignore the effect of friction.

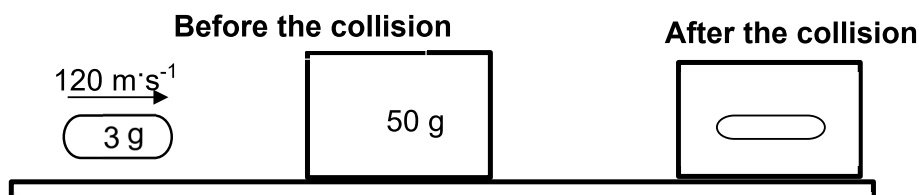

- 3.1 Define the following:
- 3.1.1 *Isolated system* (2)
- 3.1.2 *Momentum* (2)
- 3.2 Write down the magnitude of the initial momentum of the clay. (1)
- 3.3 Calculate the magnitude of the momentum of the pellet before it hits the clay. (3)
- 3.4 State the principle of conservation of linear momentum in words. (2)
- 3.5 Show by means of a calculation that the speed of the clay block, with the pellet inside, is $7,2 \text{ m}\cdot\text{s}^{-1}$ after the collision. (3)
- 3.6 Determine by means of calculations whether the above collision is ELASTIC or INELASTIC. (5)

[18]

QUESTION 4 (Start on a new page.)

A boy uses a rope to pull a toy car on a rough surface. The rope makes an angle of 30° with the horizontal. The boy exerts a 15 N force. The toy car moves a distance of 5 m while the boy exerts the force.

The frictional force experienced by the toy car during this process is 2 N.

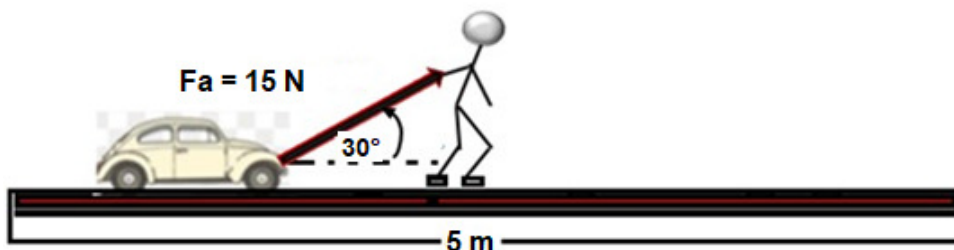

- 4.1 Define the term *work done*. (2)
- 4.2 Calculate the work done by the applied force. (4)
- 4.3 The diagram below shows a 1,5 kg block sliding from REST at point **A** to point **B** along a FRICTIONLESS surface. The height at **A** is 12 m and at **B** it is 7,5 m. Ignore the effect of air resistance.

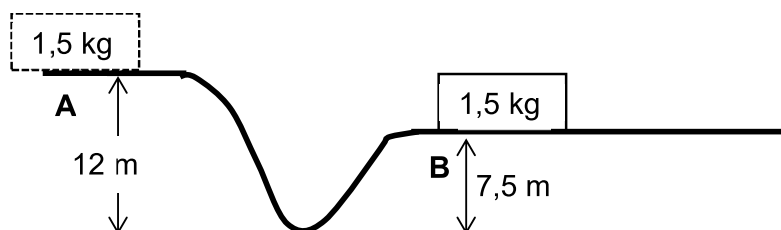

- 4.3.1 State the principle of conservation of mechanical energy in words. (2)
- 4.3.2 Calculate the speed of the block at **B**. (4)

When the block reaches **B**, it continues to slide along the ROUGH, HORIZONTAL surface and comes to rest at point **C** due to a kinetic frictional force of 4,41 N as shown in the diagram.

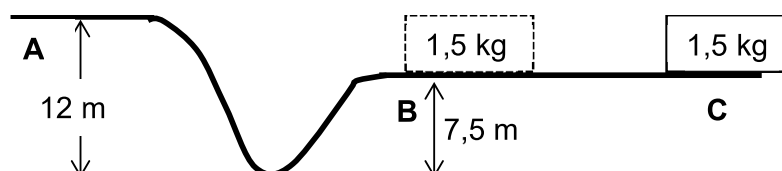

- 4.3.3 Define the term *kinetic frictional force*. (2)
- 4.3.4 Is the mechanical energy conserved while the block moves from **B** to **C**? Give a reason for your answer. (2)
- 4.3.5 Calculate the work done on the block by the kinetic frictional force if the distance between **B** and **C** is 2 m. (3)
- 4.3.6 Calculate the rate at which work is done on the block by the kinetic frictional force if it takes the block 5 s to move from **B** to **C**. (3)

[22]

QUESTION 5 (Start on a new page.)

5.1 When a deforming force is applied to a body, a restoring force develops inside the body to oppose the effect of the deforming force.

5.1.1 Define the term *elasticity*. (2)

5.1.2 Distinguish between a *perfectly elastic body* and a *perfectly plastic body*. (2)

5.2 A cylindrical wire with a length of 1 500 mm experiences stress of 9,5 kPa when a force of 12 kN is exerted on it.



5.2.1 Calculate the cross-sectional area of the wire. (3)

5.2.2 The length of the wire increases by 12 cm when the 12 kN force is applied on it. Calculate the strain that the wire experiences. (3)

5.3 Two learners embark on a science project aiming to produce a body lotion from affordable materials. To decant the lotion into smaller containers and to increase the rate of flow of the lotion, the temperature of the mixture is increased.

5.3.1 Define the term *viscosity*. (2)

5.3.2 Will the increase of heat on the mixture cause the viscosity to INCREASE, DECREASE or REMAIN THE SAME? (1)

[13]

QUESTION 6 (Start on a new page.)

- 6.1 The diagram below represents a plain mirror placed on the table. Use the diagram to answer the questions that follow.

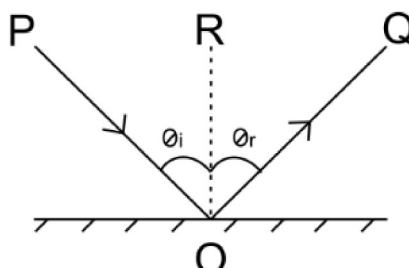

- 6.1.1 State the law of reflection. (2)
- 6.1.2 Provide labels for **R** and **Q**. (2)
- 6.2 In the diagrams below a ray of light moves from MEDIUM 1 to MEDIUM 2, while the angle of incidence is gradually increased.

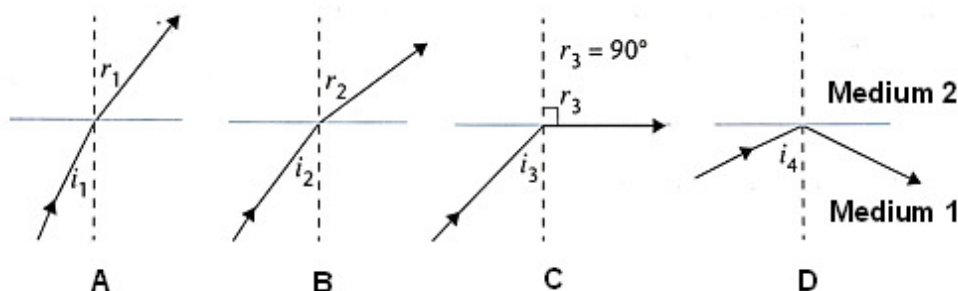

- 6.2.1 Define the term *critical angle*. (2)
- 6.2.2 Write down the name of the phenomenon represented that is illustrated in diagram **D**. (1)
- 6.2.3 Which medium in diagram **D** has the highest density? Write only MEDIUM 1 or MEDIUM 2. (1)
- 6.2.4 Which angle of incidence in the diagrams above is the critical angle? (1)
- 6.3 Draw a ray diagram to determine the position and size of the image that will be formed when the focal point distance (F) for a convex lens is 30 mm and an object with a height of 20 mm is placed at a distance of $2F$. (4)

[13]

QUESTION 7 (Start on a new page.)

- 7.1 Define *electromagnetic wave*. (2)
- 7.2 Which property of X-rays makes it suitable to take pictures of bones in human bodies? (1)
- 7.3 Write down the NAME of the electromagnetic wave that is used in the following:
- 7.3.1 To detect counterfeit notes (1)
- 7.3.2 To kill cancer cells (1)
- 7.4 What is a *photon*? (1)
- 7.5 Calculate the energy of light with a wavelength of $5,10 \times 10^{-11}$ m. (5)
- [11]**

QUESTION 8 (Start on a new page.)

- 8.1 Define the term capacitor. (2)
- 8.2 Name THREE factors affecting capacitance. (3)
- 8.3 Calculate the voltage of a battery connected to a parallel plate capacitor with a plate area of $2,0 \text{ cm}^2$ and a plate separation of 2 mm if the charge stored on the plates is 4,0 pico coulomb. (6)
- [11]**

QUESTION 9 (Start on a new page.)

The circuit diagram shows three resistors connected to a battery with negligible internal resistance. Two resistors of $6\ \Omega$ and $10\ \Omega$ are connected in series. This combination is connected in parallel to a $4\ \Omega$ resistor, which is functioning at a power rating of $36\ \text{W}$.

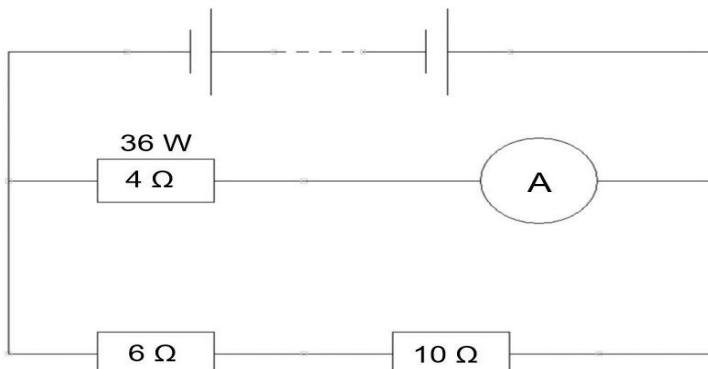

- 9.1 Define *power* in words. (2)
- 9.2 Calculate the following:
- 9.2.1 Current registered by the ammeter (A) (3)
- 9.2.2 Potential difference across the $4\ \Omega$ resistor (3)
- 9.2.3 Current in the $10\ \Omega$ resistor (4)
- [12]**

QUESTION 10 (Start on a new page.)

A coil, with an area of $2,29 \times 10^{-3}\ \text{m}^2$, consists of 75 turns. The coil is in a magnetic field that is perpendicular to the area of the coil. The magnetic flux density is $0,4\ \text{T}$.

- 10.1 State Lenz's law. (2)
- 10.2 Calculate the magnetic flux. (3)
- 10.3 The MAGNETIC FLUX changes TO ZERO during a time interval of $0,05\ \text{s}$ due to the motion of the coil. Calculate the induced emf. (3)
- [8]**

TOTAL: 150

**DATA FOR TECHNICAL SCIENCES GRADE 12
PAPER 1**

**GEGEWENS VIR TEGNIESE WETENSKAPPE GRAAD 12
VRAESTEL 1**

TABLE 1: PHYSICAL CONSTANTS/TABEL 1: FISIIESE KONSTANTES

NAME/NAAM	SYMBOL/SIMBOOL	VALUE/WAARDE
Acceleration due to gravity <i>Swaartekragversnelling</i>	g	9,8 m·s ⁻²
Speed of light in a vacuum <i>Spoed van lig in 'n vakuum</i>	c	3,0 x 10 ⁸ m·s ⁻¹
Planck's constant <i>Planck se konstante</i>	h	6,63 x 10 ⁻³⁴ J·s
Electron mass <i>Elektronmassa</i>	m _e	9,11 x 10 ⁻³¹ kg
Permittivity of free space <i>Permittiwiteit van vrye ruimte</i>	ε ₀	8,85 x 10 ⁻¹² F·m ⁻¹

TABLE 2: FORMULAE/TABEL 2: FORMULES

FORCE/KRAG

$F_{\text{net}} = ma$	$p = mv$
$f_s^{\text{max}} = \mu_s N$	$f_k = \mu_k N$
$F_{\text{net}} \Delta t = \Delta p$ $\Delta p = mv_f - mv_i$	$F_g = mg$
$MA = \frac{L}{E} = \frac{e}{I}$	

WORK, ENERGY AND POWER/ARBEID, ENERGIE EN DRYWING

$W = F\Delta x \cos\theta$	$U = mgh$ or/of $E_p = mgh$
$K = \frac{1}{2}mv^2$ or/of $E_k = \frac{1}{2}mv^2$	$W_{\text{net}} = F_{\text{net}}\Delta x \cos\theta$
$P_{\text{ave}} = Fv_{\text{ave}}$ / $P_{\text{gemid}} = Fv_{\text{gemid}}$	$P = \frac{W}{\Delta t}$
	$M_E = E_k + E_p$

ELASTICITY, VISCOSITY AND HYDRAULICS/ELASTISITEIT, VISKOSITEIT EN HIDROULIKA

$\sigma = \frac{F}{A}$	$\epsilon = \frac{\Delta l}{L}$
$\frac{\sigma}{\epsilon} = K$	$\frac{F_1}{A_1} = \frac{F_2}{A_2}$
$P = \frac{F}{A}$	$P = \rho gh$

ELECTROSTATICS / ELEKTROSTATIKA

$C = \frac{Q}{V}$	$C = \frac{\epsilon_0 A}{d}$
-------------------	------------------------------

CURRENT ELECTRICITY/STROOMELEKTRISITEIT

$R = \frac{V}{I}$	emf/emk (\mathcal{E}) = $I(R + r)$
$R_s = R_1 + R_2 + \dots$ $\frac{1}{R_p} = \frac{1}{R_1} + \frac{1}{R_2} + \dots$	$q = I \Delta t$
$W = VQ$ $W = VI \Delta t$ $W = I^2 R \Delta t$ $W = \frac{V^2 \Delta t}{R}$	$P = \frac{W}{\Delta t}$ $P = VI$ $P = I^2 R$ $P = \frac{V^2}{R}$

ELECTROMAGNETISM/ELEKTROMAGNETISME

$\Delta \phi = BA$	$\mathcal{E} = -N \frac{\Delta \phi}{\Delta t}$
$\frac{V_s}{V_p} = \frac{N_s}{N_p}$	

WAVES, SOUND AND LIGHT / GOLWE, KLANK EN LIG

$v = f\lambda$	$T = \frac{1}{f}$
$E = hf$ or $E = h \frac{c}{\lambda}$	