

# SA's Leading Past Year

## Exam Paper Portal



You have Downloaded, yet Another Great Resource to assist you with your Studies 😊

Thank You for Supporting SA Exam Papers

Your Leading Past Year Exam Paper Resource Portal

Visit us @ [www.saexampapers.co.za](http://www.saexampapers.co.za)



**SA EXAM  
PAPERS**  
SA EXAM  
PAPERS

### INSTRUCTIONS AND INFORMATION

1. The question paper consists of FOUR questions.
2. Answer ALL the questions.
3. ALL drawings are in first angle orthographic projection unless otherwise stated.
4. ALL drawings must be prepared using pencil and instruments, unless otherwise stated.
5. ALL answers must be drawn accurately and neatly.
6. ALL the questions must be answered on the QUESTION PAPER, as instructed.
7. ALL the pages must be re-stapled in numerical sequence and handed in irrespective of whether the question was attempted or not.
8. Time management is essential in order to complete all the questions.
9. Print your name and class in the block provided on every page.
10. Any details or dimensions not given must be assumed in good proportion.



JUNE EXAMINATION  
GRADE 12  
2024

## ENGINEERING GRAPHICS AND DESIGN PAPER 1

ENGINEERING GRAPHICS & DESIGN P1



C2771E

MARKS:100

TIME: 3 hours

X05



This question paper consists of 6 pages.

FOR OFFICIAL USE ONLY						
QUESTION	MARKS OBTAINED	1/2	SIGN	MODERATED	1/2	SIGN
1						
2						
3						
4						
TOTAL	200	0	0	2	0	0

FINAL CONVERTED MARK

100

CHECKED BY

COMPLETE THE FOLLOWING

NAME AND SURNAME

NAME AND SURNAME

CLASS AND TEACHER

CLASS AND TEACHER

DO NOT FOLD THE QUESTION PAPER IN HALF

QUESTION 1: ANALYTICAL (CIVIL)	
<p><b>Given:</b> The site plan of an existing building with a proposed new extension, a title panel and a table of questions. The drawing has not been presented to the indicated scale.</p> <p><b>Instructions:</b> Complete the table below by neatly answering the questions, which refer to the accompanying drawing, title panel and civil content. [30]</p>	
QUESTIONS	ANSWERS
1. What scale is indicated for the site plan?	1
2. In which city can the architectural company be found?	1
3. Name the company that printed the site plan?	1
4. Who is the client?	1
5. What is the project number?	1
6. What is the first revision?	1
7. What does the symbol at 1 indicate?	1
8. What is the width of Marvel Street in metres?	1
9. Name the feature at 2.	1
10. Which corner is the lowest corner on STAND 24?	1
11. What does the abbreviation IC stand for?	1
12. How many palm trees are on STAND 24?	1
13. Name the feature at 3.	1
14. What do the arcs at 4 indicate?	1
15. What does the dimension at 5 indicate?	1
16. With regards to the building regulations, why would the proposed new extension NOT be accepted?	1
17. What natural feature is south of STAND 24?	1
18. What does the arrow on the municipal sewer line indicate?	2
19. Why can nothing be built on the STAND next to boundary AB?	2
20. In the space below (ANSWER 20), determine the perimeter of stand 24 in metres.	3
21. In the space below (ANSWER 21), determine the total area of the existing building in square meters.	3
22. In the space in the title panel (ANSWER 22), draw, in neat freehand, the elevation and plan of the SANS 10143 graphical symbol for a wall-mounted URINAL.	3
<b>TOTAL</b>	
<b>30</b>	

**NOTE:**  
Contractors must verify all dimensions and levels on site before commencing work. Architects to be notified immediately of any discrepancies.

ARCHITECT'S SIGNATURE: .....

CLIENT'S SIGNATURE: .....

**ANSWER 22:**  
In the space below, draw, in neat freehand, the elevation and plan of the SANS 10143 graphical symbol for a wall-mounted URINAL.

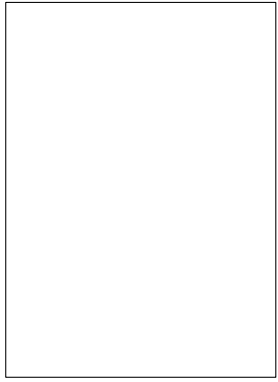

REVISION	DATE	DESCRIPTION
2	2023-06-22	ADD A NEW DRIVEWAY
1	2023-06-11	ADD A LEGEND

**SPIDER ARCHITECTS**  
11 WEB STREET  
NEW YORK  
www.spidey.com  
011 842 1565

PRINTED BY: HAWKEYE PRINTS  
DATE OF PRINT: 2024-04-25  
DRAWING TITLE: **SITE PLAN**

PROJECT: PROPOSED NEW EXTENSION FOR T. STARK  
MARVEL STREET  
CENTRAL CITY  
2055

PROJECT NUMBER: EGD2024P1-GDE  
DRAWING NUMBER: ACAD/DR/24-01

DATE: 2024-02-01  
DRAWN: DANVERS  
CHECKED: PARKER  
REFERENCE CODE: 08 - EGD235 - 678  
SCALE: 1 : 400

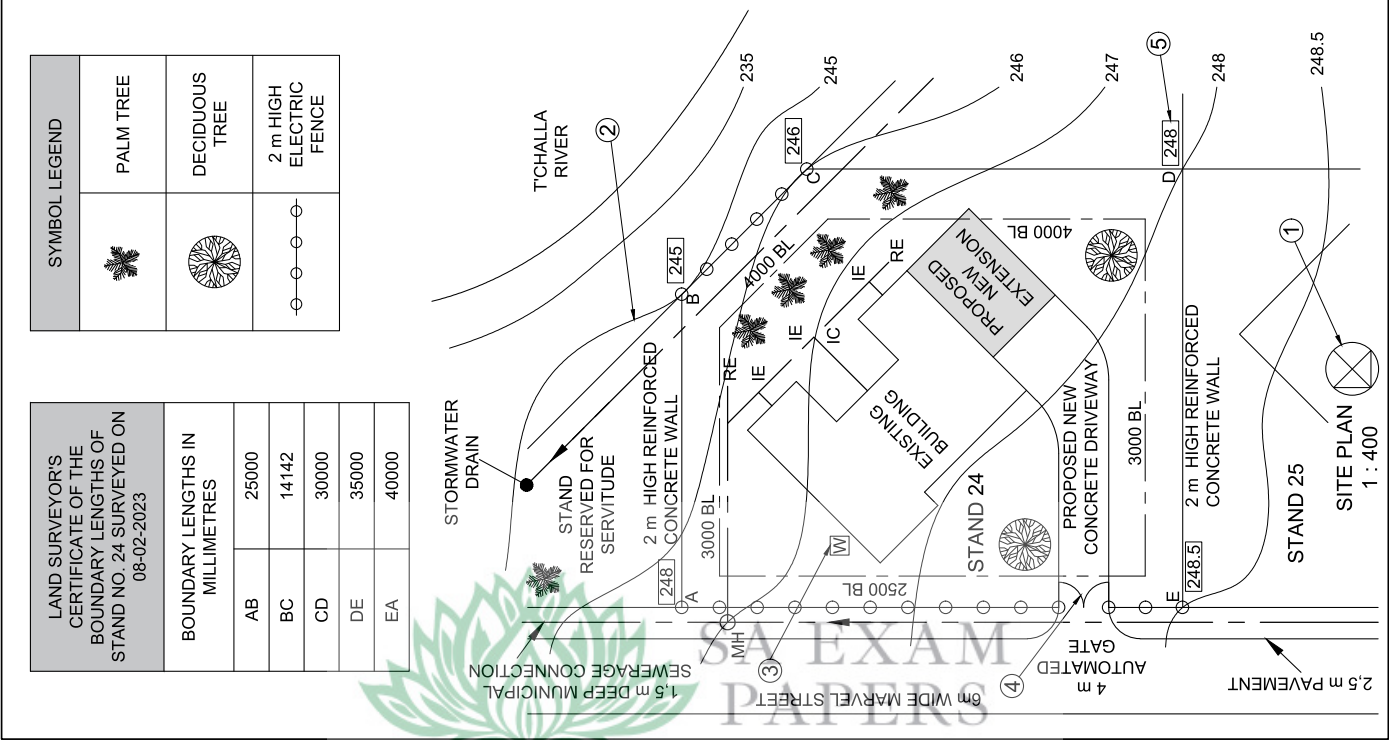

**QUESTION 2: SOLID GEOMETRY****Given:**

- The front view of a right regular hexagonal prism and a right regular pentagonal pyramid.
- An auxiliary view for the front view of the prism.
- The top view of the pyramid, as well as the axis and an auxiliary view of the prism.
- Cutting plane C-C.

**Specifications:**

- The two solids do NOT touch.
- Both solids are cut by cutting plane C-C.

**Instructions:**

Draw, to scale 1:1, the following views of the TWO solids:

- The given front view
- A sectional top view
- A sectional left view
- The true shape of the cut surfaces of both solids

- Planning is essential.
- Show ALL hidden detail.
- Show ALL construction.

[38]

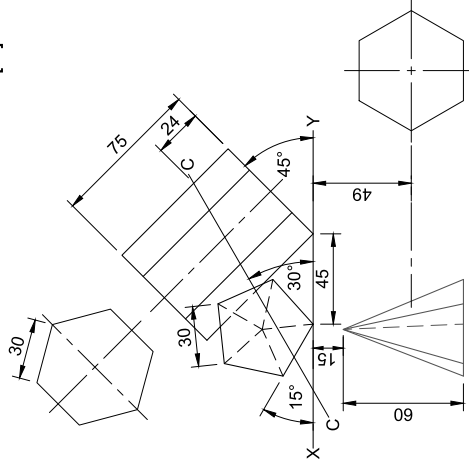
**ASSESSMENT CRITERIA**

1	FRONT VIEW + AUX	10
2	SECTIONAL TOP VIEW	10 ½
3	SECTIONAL LEFT VIEW	10 ½
4	TRUE SHAPES	7
TOTAL		38

NAME AND SURNAME

CLASS

3

Please turn over



**QUESTION 3: PERSPECTIVE**

**Given:**

Two views of a house and the information needed to draw a two-point perspective drawing.

- PP - Picture Plane
- HL - Horizon Line
- GL - Ground Line
- SP - Station Point

**Instructions:**

Complete the perspective drawing.

- Align the drawing sheet with the ground line (GL).
- Determine and label the vanishing points.
- Show ALL construction.
- Show the depth at the door and the window.
- No hidden or internal detail is required.

[38]

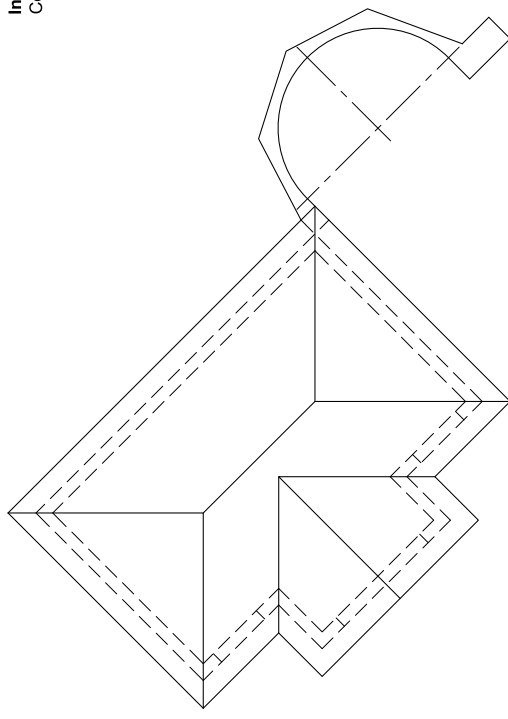

ASSESSMENT CRITERIA		
1	CONSTRUCTION	6
2	WALLS, DOOR + WINDOW	20
3	ROOF	6
4	ARCH WALL	6
TOTAL		38

PP \_\_\_\_\_

HL \_\_\_\_\_

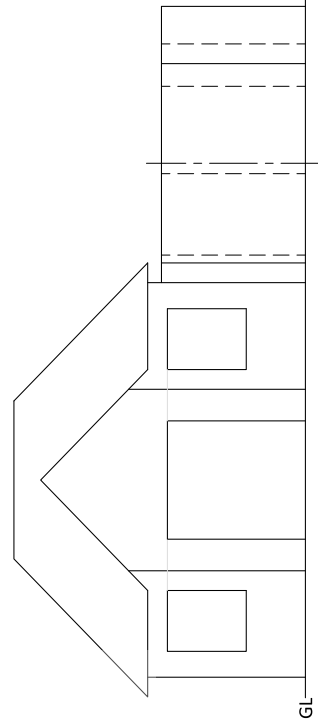

NAME AND SURNAME

CLASS

4

Please turn over



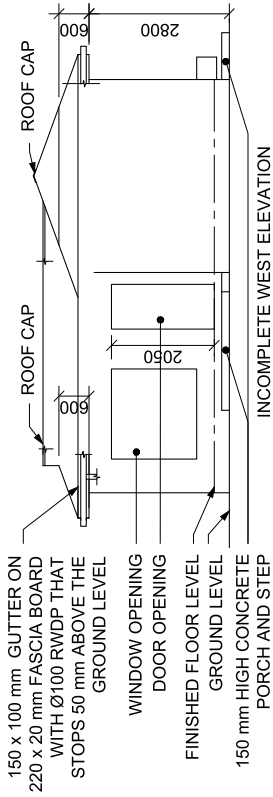

**QUESTION 4 - CIVIL DRAWING**

**Given:**

- The incomplete west elevation of a house showing the walls, the window and door openings, the porch, the step and wash tub, the roof and labels
- An incomplete floor plan, showing the walls, the position of the windows, doors and fixtures, the electrical layout and the complete roof line
- An incomplete schematic diagram of a roof truss at cutting plane A-A and roof notes
- Room designations and floor finishes
- A table of roof components and a table of electrical symbols
- A table of fixtures
- An incomplete foundation and external wall detail
- A door and window schedule
- The incomplete floor plan, drawn to scale 1 : 50, and the incomplete foundation and break lines of the detailed section, drawn to scale 1 : 20, on page 6

**FLOOR FINISHES**

- BEDROOM: WOOD
- BATHROOM: TILES
- ENTRANCE FOYER: WOOD
- KITCHEN: WOOD
- PORCH: SLATE

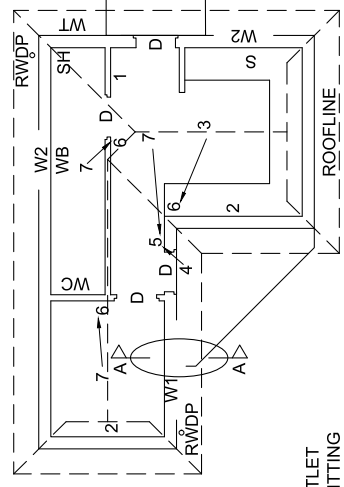

INCOMPLETE FLOOR PLAN

ROOF COMPONENTS		ELECTRICAL SYMBOLS	
500	ROOF CAP		
	FASCIA BOARD 220 x 20		
	GUTTER 150 x 100		

ROOF COMPONENTS		ELECTRICAL SYMBOLS	
500	ROOF CAP		
	FASCIA BOARD 220 x 20		
	GUTTER 150 x 100		

- FIXTURES**
- WC TOILET
  - WB WASH BASIN
  - SH SHOWER
  - S SINGLE SINK
  - WT WASH TUB
- ELECTRICAL FITTINGS**
- DISTRIBUTION BOARD
  - SWITCHED SOCKET OUTLET
  - FLUORESCENT LIGHT FITTING
  - 1 x 40W
  - WALL MOUNTED LIGHT
  - ONE-WAY SWITCH - DOUBLE
  - ONE-WAY SWITCH - SINGLE
  - POLE
  - POLE
  - CEILING LIGHT

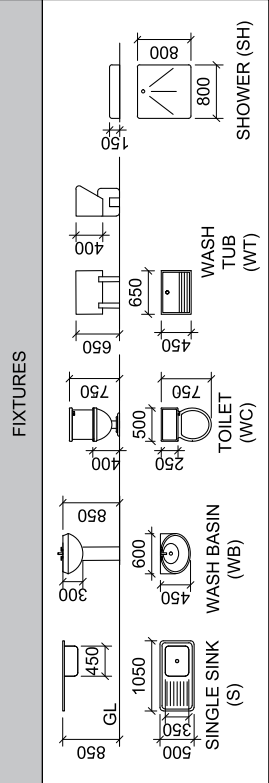

FIXTURES

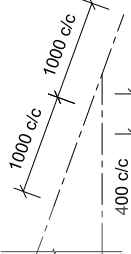

INCOMPLETE SCHEMATIC DIAGRAM OF A PART OF A ROOF TRUSS AT CUTTING PLANE A-A

ROOF NOTES:  
ROOF PITCH 20°

- 114 x 40 mm ROOF TRUSSES ON 114 X 40 mm WALL PLATES
- 500 mm ROOF OVERHANG TO END OF ROOF TRUSS
- 20 mm IBR ROOF SHEETING ON 80 x 50 mm PURLINS @1000 mm c/c
- 220 x 20 mm FASCIA BOARDS WITH 150 X 100 mm GUTTERS ON ALL SIDES
- 10 mm CEILING BOARDS ON 40 x 40 mm BRANDERING STRIPS @ 400 mm c/c

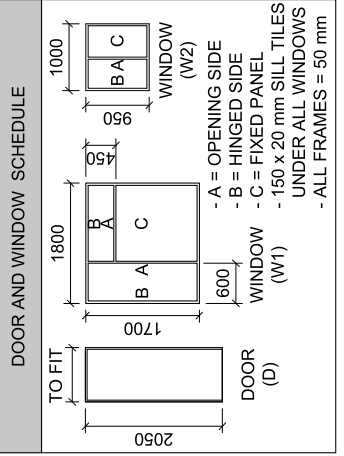

DOOR AND WINDOW SCHEDULE

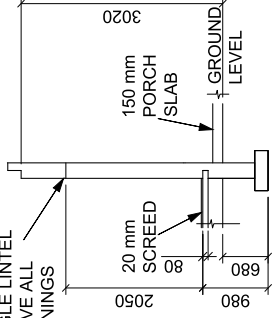

INCOMPLETE FOUNDATION AND EXTERNAL WALL DETAIL

**Label the following:**

- The west elevation
- The floor finishes
- Ground level, finished floor level and the damp-proof course (use the correct abbreviations and show it on all relevant views)

**NOTE:**

- ALL drawing must comply with the **guidelines and graphical symbols** contained in the SANS 701:43.
- No hidden detail is required.

[94]

ROOF DETAIL		FOR OFFICIAL USE ONLY
A	ROOF ANGLE	1
B	ROOF COVER & PURLINS	2
C	RAFTER AND THE BENT	3 1/2
D	FASCIA, GUTTER & RIDGE	2
E	BRANDING, WALL PLATE & CEILING	2
SUBTOTAL		10 1/2
INCORRECT SCALE		(-2)
NON-ALIGNMENT OF VIEWS (-2)		
VIEWS ROTATED (-2)		
SECTION VIEWED INCORRECTLY (-2)		
INCORRECT LETTERING (-1)		
BREAK LINE (-1)		
TOTAL		

ASSESSMENT CRITERIA		
FLOOR PLAN		
	POSSIBLE	OBTAINED
1	DOORS + WINDOWS + ROOF LINE	15 1/2
2	FIXTURES	9
3	ELECTRICAL	9
4	HATCHING	3
5	LABELS	2 1/2
SUBTOTAL		39
WEST ELEVATION		
1	ROOF + RWDP	10
2	WALLS + FFL + PORCH + WASH TROUGH	6 1/2
3	DOOR + WINDOW	7 1/2
4	LABELS	1
SUBTOTAL		25

DETAILED SECTION A-A		
1	ROOF DETAIL	10 1/2
2	FOUNDATION + WALL + DOOR + FIXTURE	9 1/2
3	WINDOW & DOOR	3
4	HATCHING	6
5	LABELS	1
SUBTOTAL		30
PENALTIES (-)		
TOTAL		94
NAME AND SURNAME		
CLASS		

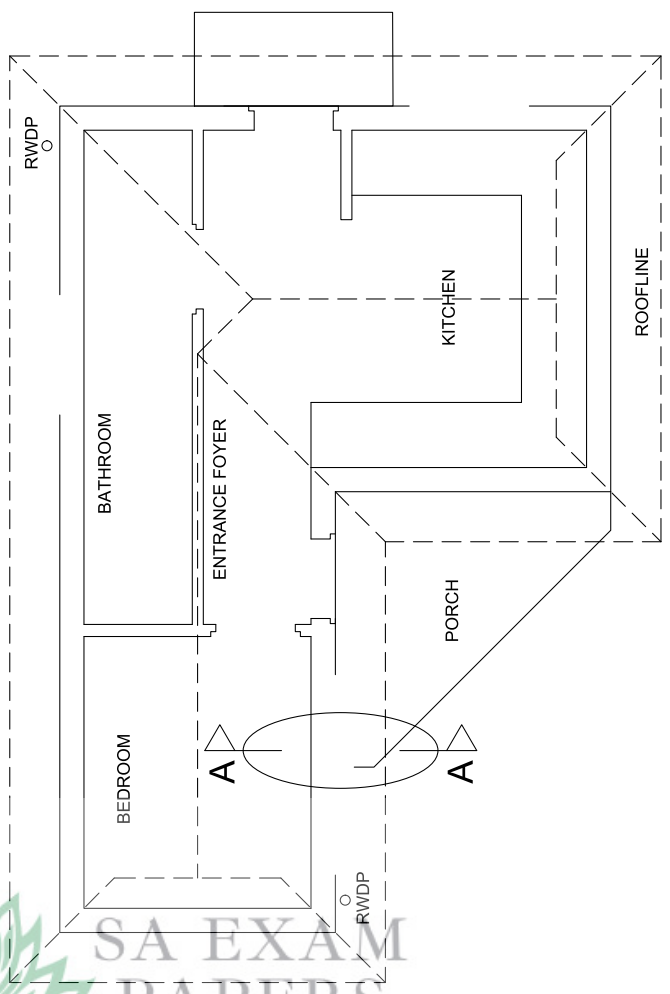
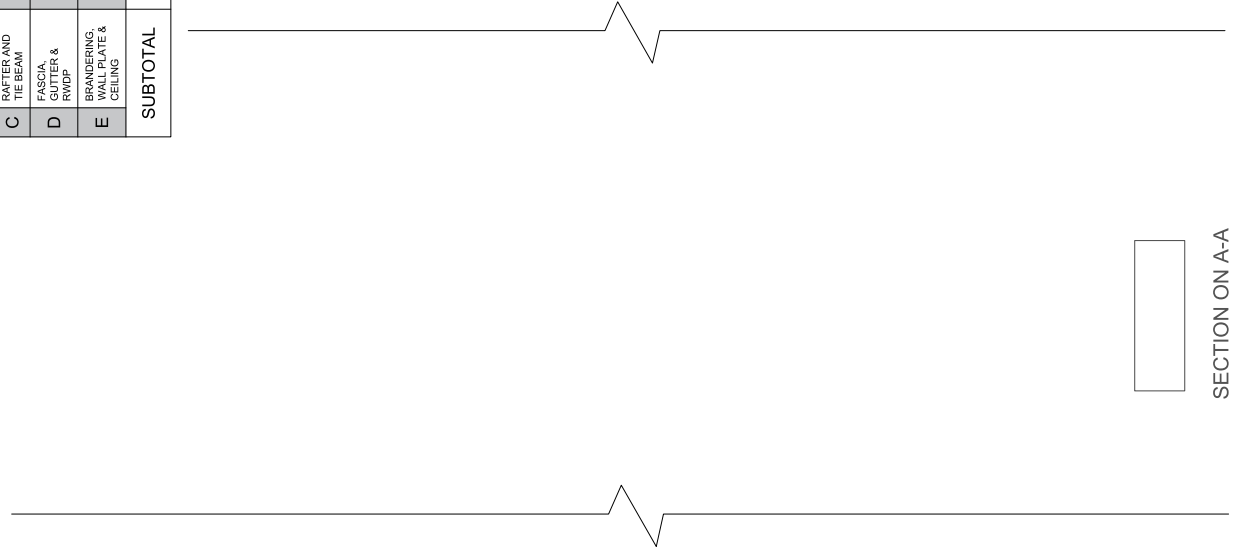

FLOOR PLAN  
SCALE 1 : 50

SECTION ON A-A  
SCALE 1 : 20

