

# SA's Leading Past Year

## Exam Paper Portal



You have Downloaded, yet Another Great Resource to assist you with your Studies 😊

Thank You for Supporting SA Exam Papers

Your Leading Past Year Exam Paper Resource Portal

Visit us @ [www.saexampapers.co.za](http://www.saexampapers.co.za)



**SA EXAM  
PAPERS**  
SA EXAM  
PAPERS



Province of the  
**EASTERN CAPE**  
EDUCATION



**NATIONAL  
SENIOR CERTIFICATE**

**GRADE 12**

**JUNE 2024**

**PHYSICAL SCIENCES P1**

**MARKS: 150**

**TIME: 3 hours**

---

This question paper consists of 17 pages, including 3 datasheets.

---



**INSTRUCTIONS AND INFORMATION**

1. Write your NAME in the appropriate space on the ANSWER BOOK.
2. Answer ALL the questions.
3. You may use a non-programmable calculator.
4. You may use appropriate mathematical instruments.
5. Number the answers correctly according to the numbering system used in this question paper.
6. You are advised to use the attached DATA SHEETS.
7. The formulae and substitutions must be shown in ALL calculations.
8. Give brief motivations, discussions, et cetera where required.
9. Round off your FINAL numerical answers to a minimum of TWO decimal places.
10. Start EACH question on a NEW page.
11. All diagrams are not necessarily drawn according to scale.
12. Write neatly and legibly.

**QUESTION 1: MULTIPLE-CHOICE QUESTIONS**

Various options are provided as possible answers to the following questions. Each question has only ONE correct answer. Choose the answer and write ONLY the letter (A–D) next to the question numbers (1.1–1.10) in the ANSWER BOOK, for example 1.11 B.

- 1.1 According to Newton's Second Law of Motion, the net force acting on an object is:
- A Equal to the acceleration of the object.
  - B Inversely proportional to the acceleration of the object.
  - C Indirectly proportional to the acceleration of the object.
  - D Directly proportional to the acceleration of the object. (2)
- 1.2 Two isolated bodies, **A** and **B**, with masses **m** and **2m** respectively, are placed a distance **r** from each other.

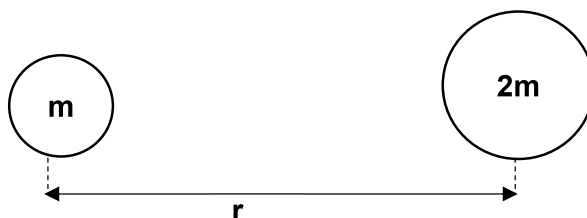

Consider the following statements regarding the gravitational force exerted by bodies **A** and **B** on each other.

- (i) The force exerted by **B** on body **A** is half that exerted by **A** on body **B**.
- (ii) The force exerted on the bodies is independent of the masses of the bodies.
- (iii) The force exerted on body **A** by **B** is equal but opposite to that exerted on body **B** by **A**.
- (iv) The forces will always be attractive.

Which of the statements above is/are TRUE?

- A (i), (ii) and (iv) only
- B (ii), (iii) and (iv) only
- C (iii) and (iv) only
- D (iv) only (2)

- 1.3 Three identical spheres, **P**, **Q** and **R**, with masses  $M_P = m$ ,  $M_Q = 2m$  and  $M_R = 3m$  respectively, are dropped from the same height above the ground. Ignore the effect of air friction.

How will the acceleration of the objects compare as they fall to the ground?

A  $a_R > a_Q > a_P$

B  $a_P > a_Q > a_R$

C  $a_P = a_Q = a_R$

D  $a_R < a_Q < a_P$

(2)

- 1.4 The net work done to stop a moving object is equal to the ...

A inertia of the object.

B change in kinetic energy of the object.

C change in momentum of the object.

D change in impulse of the object.

(2)

- 1.5 Two objects experience an ELASTIC collision in an isolated system. Which ONE of the following combinations regarding the momentum and kinetic energy is correct?

	MOMENTUM	KINETIC ENERGY
A	Is not conserved	Is conserved
B	Is conserved	Is not conserved
C	Is not conserved	Is not conserved
D	Is conserved	Is conserved

(2)

- 1.6 Two forces, each of magnitude  $300\text{ N}$ , are simultaneously applied to a crate at rest on a horizontal surface as shown in the diagram below. Ignore the effects of friction.

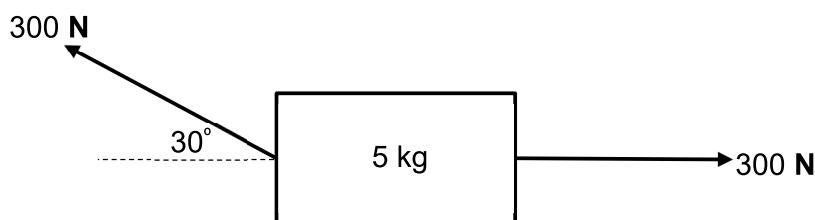

Work will be done by the net force on the crate because the crate will ...

- A be lifted off the surface.  
 B accelerate to the left.  
 C accelerate to the right.  
 D remain at rest. (2)
- 1.7 A boy, mass  $2\text{ m}$  and a girl mass  $\text{m}$ , on roller skates are holding hands and facing each other. They then push off against each other. The girl experiences force  $\text{F}$  and an acceleration  $\text{a}$ , to the left.



Which ONE of the following best describes the magnitudes of the force and acceleration experienced by the boy? Ignore the effects of friction.

	ACCELERATION ( $\text{m.s}^{-2}$ )	FORCE (N)
A	$2\text{a}$	$\frac{1}{2}\text{F}$
B	$2\text{a}$	$\text{F}$
C	$\frac{1}{2}\text{a}$	$\text{F}$
D	$\frac{1}{2}\text{a}$	$2\text{F}$

(2)

- 1.8 A sound source is moving relative to a stationary observer. As the sound source moves away from the observer, its frequency appears to decrease because the ...
- A wavelength between the source and the observer decreases.
- B wavelength between the source and the observer increases.
- C wavelength between the source and the observer remains unchanged.
- D the loudness between the source and the observer increases. (2)
- 1.9 Astronomers obtained the following spectral lines from an element from the laboratory and a distant star.

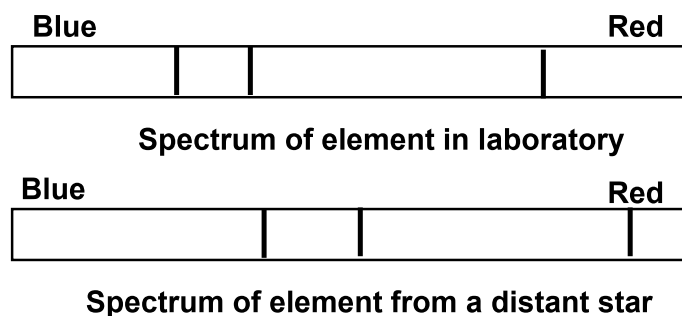

The observation confirms:

	MOVEMENT OF THE STAR	SPECTRAL LINES
A	Away from earth	Red shifted
B	Towards earth	Red shifted
C	Away from earth	Blue shifted
D	Towards earth	Blue shifted

(2)

- 1.10 In the diagram below **P** and **Q** are points from a charged sphere such that the electric fields at point **Q** is **E** and at point **P** is **9 E**. Determine the distance **x** in terms of **r**.

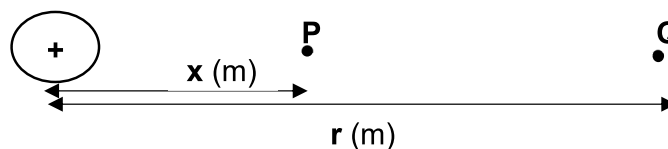

- A  $\frac{1}{3} r$
- B  $\frac{1}{2} r$
- C  $\frac{1}{6} r$
- D  $\frac{2}{3} r$

(2)  
[20]

**QUESTION 2 (Start on a new page.)**

A block of mass 20 kg is at rest on a rough horizontal surface. The block is connected with a light inextensible string, that is hanging over a frictionless pulley, to another block of mass  $X$  kg. A force of 105 N is applied to the 20 kg block at an angle of  $25^\circ$  to the horizontal to accelerate the system at  $2 \text{ m}\cdot\text{s}^{-2}$  to the right as shown in the diagram below.

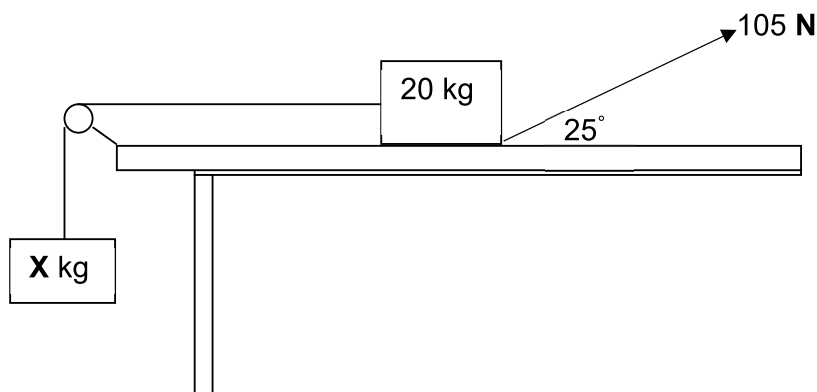

- 2.1 Define the term *kinetic frictional force* in words. (2)
- 2.2 Draw a free-body diagram of all the forces acting on the 20 kg block. (5)
- 2.3 The coefficient of kinetic friction ( $\mu_k$ ) between the block and the surface is 0,2.
- Calculate the:
- 2.3.1 Kinetic frictional force acting on the 20 kg block (4)
- 2.3.2 Tension in the string that connects the two blocks (4)
- 2.3.3 Mass  $X$ , of the hanging block (2)
- [17]**



**QUESTION 3 (Start on a new page.)**

A spaceship with a mass of 1 500 kg is orbiting the earth at a distance,  $2 \times 10^5$  km from the centre of the earth as shown in the diagram below.

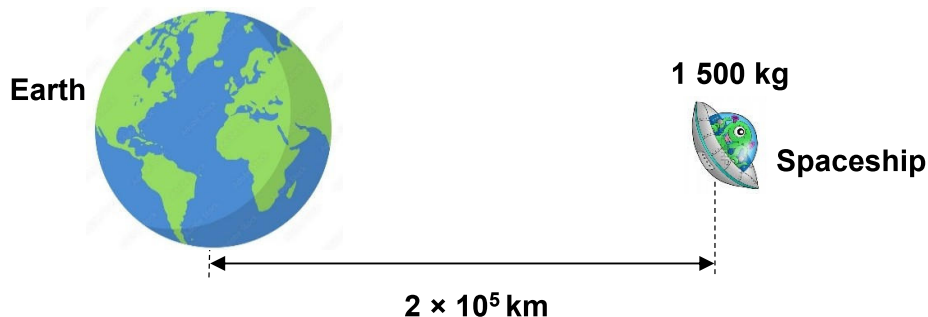

- 3.1 State Newton's Law of Universal Gravitation in words. (2)
- 3.2 Calculate the force that the earth exerts on the spaceship. (4)
- 3.3 How does the magnitude of the force that the spaceship exerts on Earth compare to the answer calculated in QUESTION 3.2? State a relevant law to support your answer. (2)
- 3.4 The spaceship now orbits closer to the Earth at a new distance of  $1 \times 10^8$  m from the centre of the earth. Calculate the acceleration of the spaceship at this position. (4)

**[12]**

**QUESTION 4 (Start on a new page.)**

Ball **A** is thrown vertically upwards from the bottom (foot) of a building which is  $h$  metres high with a speed of  $15 \text{ m}\cdot\text{s}^{-1}$ . After  $0,5 \text{ s}$ , ball **B** is also thrown vertically upwards from the top of the building. Both balls reach a maximum height at point **P** at the same time as shown in the diagram below. Ignore the effects of air friction.

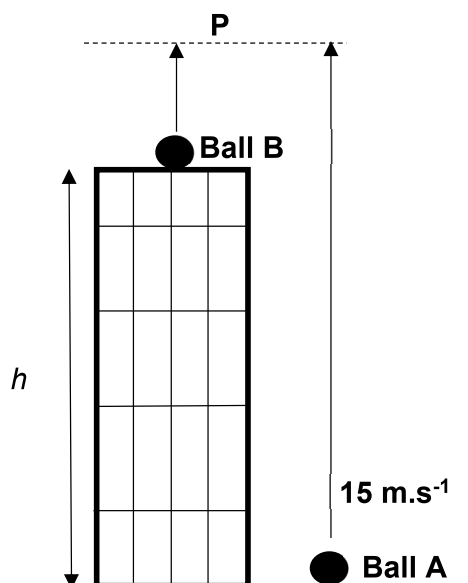

- 4.1 Define the term *projectile motion* in words. (2)
- 4.2 Calculate:
- 4.2.1 The time taken for ball **A** to return to the ground (3)
- 4.2.2 The speed at which ball **B** is thrown upwards (4)
- 4.2.3 The height of the building  $h$  (5)
- 4.2.4 How does the velocity of ball **A** compare to that of ball **B** at the instant when the two balls hit the ground? Give a reason for your answer. (2)
- 4.3 On the same set of axes, sketch the velocity-time graph for the motion of the balls **A** and **B** from the moment they are thrown vertically upwards until they reach the ground.

Indicate the following in the graph:

- Initial velocity of both balls, **A** and **B**
- The time when the two balls, **A** and **B** are at the maximum height
- The time when the two balls, **A** and **B** reach the ground

(5)  
[21]

**QUESTION 5 (Start on a new page.)**

A truck of mass 1 500 kg travelling at a constant speed of  $20 \text{ m}\cdot\text{s}^{-1}$  to the west along a straight horizontal road collides with a stationary car of mass 900 kg and the two vehicles moved together after the collision. The collision lasted for 0,2 s. Ignore the effect of friction.



- 5.1 Explain what is meant by the term *isolated system*. (2)
- 5.2 State the principle of conservation of linear momentum in words. (2)
- 5.3 Calculate the:
- 5.3.1 Speed of the vehicles after collision (4)
- 5.3.2 Net force exerted by the truck on the car (4)
- 5.4 Is the collision ELASTIC or INELASTIC? Use relevant calculations to explain your answer. (5)
- 5.5 Delicate equipment is usually packaged using bubble wrap for safety of the equipment. Explain how this process keeps the equipment safe. (3)
- [20]**

**QUESTION 6 (Start on a new page.)**

The diagram below shows a boy skateboarding on a ramp which is inclined at  $30^\circ$  to the horizontal. A constant frictional force of  $50 \text{ N}$  acts on the skateboard as it moves from point **A** to point **B**. Consider the boy and the skateboard as a single unit of mass  $60 \text{ kg}$ . Ignore the effects of air friction.

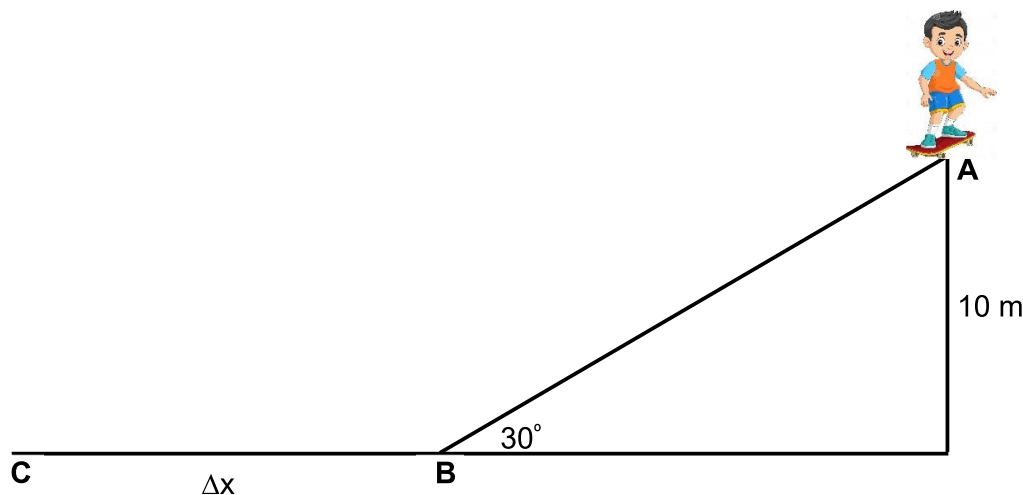

- 6.1 Draw a free-body diagram showing ALL the forces acting on the skateboard while it is moving down the incline. (3)
- 6.2 Use energy principle to calculate the speed of the boy-skateboard unit at point **B**. (6)
- 6.3 Point **C** is  $\Delta x$  meters to the left of point **B**. The boy-skateboard unit comes to rest at point **C**. The coefficient of kinetic frictional force ( $\mu_k$ ) for the surface **BC** is 0,15.
- 6.3.1 State the work-energy theorem in words. (2)
- 6.3.2 Use the work-energy theorem to calculate the distance  $\Delta x$  that the boy-skateboard unit moved before coming to rest at point **C**. (5)
- [16]**

**QUESTION 7 (Start on a new page.)**

A helicopter hovers at a height of 30 m above the ground. It lowers a package of mass 150 kg vertically downwards at a constant velocity onto the ground as shown in the diagram below. The tension in the cable is 950 N. Air friction is NOT to be ignored.

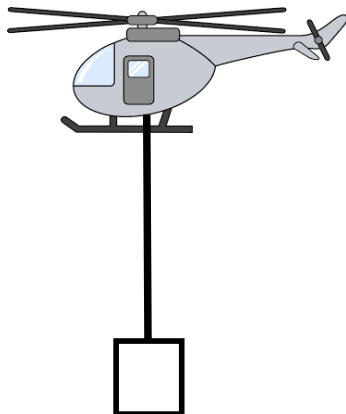

- 7.1 Define the term *non-conservative force*. (2)
- 7.2 Identify TWO non-conservative forces acting on the package during its downward motion. (2)
- 7.3 Draw a free-body diagram showing ALL the forces acting on the package while it is being lowered to the ground. (3)
- 7.4 Use ENERGY PRINCIPLES to calculate the magnitude of the air friction acting on the package as it is lowered to the ground. (5)
- [12]**

**QUESTION 8 (Start on a new page.)**

An observer walks at a constant velocity towards a stationary sound source that emits sound at a frequency of 2 450 Hz. The frequency detected by the observer as she approaches the sound source is 2 500 Hz.

8.1 State the Doppler effect in words. (2)

8.2 Explain in terms of wave motion why the detected frequency is higher than the emitted frequency. (3)

8.3 Calculate the speed of the observer as it approaches the sound source. Take the speed of sound in air as  $340 \text{ m}\cdot\text{s}^{-1}$ . (5)

8.4 How would the wavelength of the sound wave emitted by the source change in the following scenarios?

Write down only INCREASE, DECREASE or STAYS THE SAME.

When the observer:

8.4.1 Stands next to the sound source (1)

8.4.2 Moves away from the sound source (1)

8.5 The observer decides to run towards the direction of the sound source at a higher constant speed than the speed calculated in QUESTION 8.3. How will this affect the following?

Write down only INCREASES, DECREASES or STAYS THE SAME.

8.5.1 The detected frequency (1)

8.5.2 The speed of sound (1)

8.5.2 The emitted frequency from the sound source (1)

8.6 Give TWO applications of the Doppler effect in the medical field. (2)

**[17]**

## QUESTION 9

In the diagram below,  $Q_1$ ,  $Q_2$  and  $Q_3$  are three stationary point charges placed along a straight line. The distance between  $Q_1$  and  $Q_2$  is 1,0 m and the distance between  $Q_2$  and  $Q_3$  is 1,5 m, as shown in the diagram below.

DIAGRAM 1

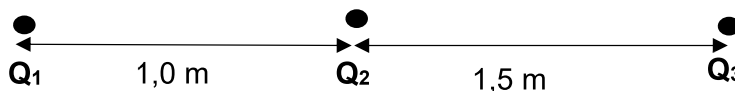

9.1 State Coulomb's law in words. (2)

9.2 The magnitude of charges  $Q_1$  and  $Q_2$  are unknown. The charge on  $Q_1$  is positive. The charge on  $Q_3$  is  $+2 \times 10^{-6}$  C and it experiences a net electrostatic force to the left.

What is the sign of the charge on  $Q_2$ ? Write down only POSITIVE or NEGATIVE. (2)

9.3 When charge  $Q_2$  is removed, the magnitude of the electrostatic force experienced by charge  $Q_3$  due to  $Q_1$  becomes 0,012 N.

DIAGRAM 2

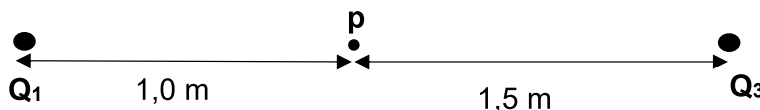

9.3.1 Calculate the magnitude of the charge now on  $Q_1$ . (4)

9.3.2 Define *electric field at a point* in words. (2)

9.3.3 Calculate the magnitude of the net electric field at point  $P$  as shown in **DIAGRAM 2** above. (5)

[15]

**TOTAL: 150**

**DATA FOR PHYSICAL SCIENCES GRADE 12  
PAPER 1 (PHYSICS)**

**GEGEWENS VIR FISIESE WETENSAPPE GRAAD 12  
VRAESTEL 1 (FISIKA)**

**TABLE 1: PHYSICAL CONSTANTS/TABEL 1: FISIESE KONSTANTES**

NAME/NAAM	SYMBOL/SIMBOOL	VALUE/WAARDE
Acceleration due to gravity <i>Swaartekragversnelling</i>	g	9,8 m•s <sup>-2</sup>
Universal gravitational constant <i>Universelegravitasiekonstant</i>	G	6,67 x 10 <sup>-11</sup> N•m <sup>2</sup> •kg <sup>-2</sup>
Speed of light in a vacuum <i>Spoeed van lig in 'n vakuum</i>	c	3,0 x 10 <sup>8</sup> m•s <sup>-1</sup>
Planck's constant <i>Planck se konstante</i>	h	6,63 x 10 <sup>-34</sup> J•s
Coulomb's constant <i>Coulomb se konstante</i>	k	9,0 x 10 <sup>9</sup> N•m <sup>2</sup> •C <sup>-2</sup>
Charge on electron <i>Lading op elektron</i>	e	-1,6 x 10 <sup>-19</sup> C
Electron mass <i>Elektronmassa</i>	m <sub>e</sub>	9,11 x 10 <sup>-31</sup> kg
Mass of earth <i>Massa op aarde</i>	M	5,98 x 10 <sup>24</sup> kg
Radius of earth <i>Radius van aarde</i>	R <sub>E</sub>	6,38 x 10 <sup>6</sup> m

**TABLE 2: FORMULAE/TABEL 2: FORMULES**

**MOTION/BEWEGING**

$v_f = v_i + a \Delta t$	$\Delta x = v_i \Delta t + \frac{1}{2} a \Delta t^2$ or/of $\Delta y = v_i \Delta t + \frac{1}{2} a \Delta t^2$
$v_f^2 = v_i^2 + 2a\Delta x$ or/of $v_f^2 = v_i^2 + 2a\Delta y$	$\Delta x = \left( \frac{v_i + v_f}{2} \right) \Delta t$ or/of $\Delta y = \left( \frac{v_i + v_f}{2} \right) \Delta t$

**FORCE/KRAG**

$F_{\text{net}} = ma$	$p = mv$
$f_s^{\text{max}} = \mu_s N$	$f_k = \mu_k N$
$F_{\text{net}} \Delta t = \Delta p$ $\Delta p = mv_f - mv_i$	$w = mg$
$F = \frac{Gm_1m_2}{d^2}$	$g = G \frac{M}{d^2}$



**WORK, ENERGY AND POWER/ARBEID, ENERGIE EN DRYWING**

$W = F\Delta x \cos \theta$	$U = mgh$ or/of $E_p = mgh$
$K = \frac{1}{2}mv^2$ or/of $E_k = \frac{1}{2}mv^2$	$W_{\text{net}} = \Delta K$ or/of $W_{\text{net}} = \Delta E_k$ $\Delta K = K_f - K_i$ or/of $\Delta E_k = E_{kf} - E_{ki}$
$W_{\text{nc}} = \Delta K + \Delta U$ or/of $W_{\text{nc}} = \Delta E_k + \Delta E_p$	$P = \frac{W}{\Delta t}$
$P_{\text{av}} = Fv$	

**WAVES, SOUND AND LIGHT/GOLWE, KLANK EN LIG**

$v = f\lambda$	$T = \frac{1}{f}$
$f_L = \frac{v \pm v_L}{v \pm v_s} f_s$ $f_L = \frac{v \pm v_L}{v \pm v_b} f_b$	$E = hf$ or/of $E = h\frac{c}{\lambda}$
$E = W_0 + E_k$ where/waar	
$E = hf$ and/en $W_0 = hf_0$ and/en $E_k = \frac{1}{2}mv^2$ or/ of $K_{\text{max}} = \frac{1}{2}mv_{\text{max}}^2$	

**ELECTROSTATICS/ELEKTROSTATIKA**

$F = \frac{kQ_1Q_2}{r^2}$	$E = \frac{kQ}{r^2}$
$E = \frac{V}{d}$	$E = \frac{F}{q}$
$V = \frac{W}{q}$	$n = \frac{Q}{q_e}$

**ELECTRIC CIRCUITS/ELEKTRIESE STROOMBANE**

$R = \frac{V}{I}$	$\text{emf} (\varepsilon) = I(R + r)$ $\text{emk} (\varepsilon) = I(R + r)$
$R_s = R_1 + R_2 + \dots$ $\frac{1}{R_p} = \frac{1}{R_1} + \frac{1}{R_2} + \dots$	$q = I \Delta t$
$W = Vq$ $W = VI\Delta t$ $W = I^2R\Delta t$ $W = \frac{V^2\Delta t}{R}$	$P = \frac{W}{\Delta t}$ $P = VI$ $P = I^2R$ $P = \frac{V^2}{R}$

**ALTERNATING CURRENT/WISSELSTROOM**

$I_{\text{rms}} = \frac{I_{\text{max}}}{\sqrt{2}}$	/	$I_{\text{wgk}} = \frac{I_{\text{maks}}}{\sqrt{2}}$	$P_{\text{average}} = V_{\text{rms}} I_{\text{rms}}$	/	$P_{\text{gemiddeld}} = V_{\text{wgk}} I_{\text{wgk}}$
$V_{\text{rms}} = \frac{V_{\text{max}}}{\sqrt{2}}$	/	$V_{\text{wgk}} = \frac{V_{\text{maks}}}{\sqrt{2}}$	$P_{\text{average}} = I_{\text{rms}}^2 R$	/	$P_{\text{gemiddeld}} = I_{\text{wgk}}^2 R$
			$P_{\text{average}} = \frac{V_{\text{rms}}^2}{R}$	/	$P_{\text{gemiddeld}} = \frac{V_{\text{wgk}}^2}{R}$