

SA's Leading Past Year

Exam Paper Portal



You have Downloaded, yet Another Great Resource to assist you with your Studies 😊

Thank You for Supporting SA Exam Papers

Your Leading Past Year Exam Paper Resource Portal

Visit us @ www.saexampapers.co.za



**SA EXAM
PAPERS**
SA EXAM
PAPERS



GAUTENG PROVINCE

REPUBLIC OF SOUTH AFRICA

JUNE EXAMINATION GRADE 12 2024

MATHEMATICAL LITERACY (PAPER 2)

TIME: 2 hours

MARKS: 100

8 pages + an addendum of 5 pages

MATHEMATICAL LITERACY P2



C2602E

X10



INSTRUCTIONS AND INFORMATION

1. This question paper consists of FOUR questions. Answer ALL the questions.
2. Use the ANNEXURES in the ADDENDUM as follows:

 Use ANNEXURE A for QUESTION 1.3
 Use ANNEXURE B for QUESTION 2.1
 Use ANNEXURE C for QUESTION 4.1
 Use ANNEXURE D for QUESTION 4.2
3. Number your answers correctly according to the numbering system used in this question paper.
4. Start EACH question on a NEW page.
5. You may use an approved calculator (non-programmable and non-graphical), unless stated otherwise.
6. Show ALL calculations clearly.
7. Round-off ALL final answers appropriately according to the given context, unless stated otherwise.
8. Indicate units of measurement, where applicable.
9. Maps and diagrams are NOT necessarily drawn to scale, unless stated otherwise.
10. Write neatly and legibly.

QUESTION 1

1.1

Phinda went to the shops to buy groceries. She checked the odometer of her car before driving. The reading on her odometer was 123 456 as indicated alongside.

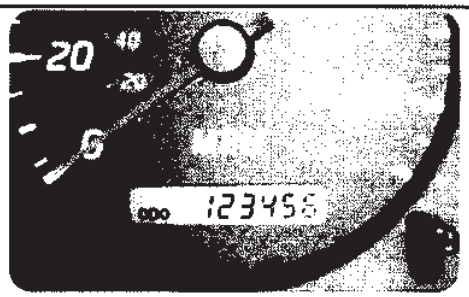
[Source: www.freepik.com]

Study the information above and use it to answer the following questions.

1.1.1 Choose the letter of the answer that will complete the following statement.

The odometer is an instrument used to measure ...

- (A) speed.
- (B) distance.

(2)

1.1.2 Express the reading on the odometer in words.

(2)

1.2 Phinda bought the following ingredients to prepare a ginger drink:

- 25 g of ginger (powder)
- 12,5 g tartaric acid
- 1 kg brown sugar
- A bucket with a capacity of 10 000 cm³

This drink serves 40 people.

NOTE:

1 teaspoon = 5 g

1 litre = 1 000 cm³

1.2.1 Define the term *capacity* in this context.

(2)

1.2.2 Express ginger to tartaric acid as a simplified ratio.

(2)

1.2.3 How many teaspoons of tartaric acid are required to prepare the ginger drink?

(2)

1.2.4 Convert 10 000 cm³ to litres.

(2)

1.2.5 Determine the amount of sugar that is required to prepare a ginger drink that can serve 200 people.

(2)

- 1.3 Phinda lives in Edenvale. She visited her friend in Springs. She decided to use the national roads to travel to her friend's house.

The map she used for travelling is shown in ANNEXURE A.

Study the map in ANNEXURE A and the information above to answer the questions that follow.

- 1.3.1 Which national road(s) must she use from Edenvale to Springs? (2)
- 1.3.2 What is the general direction from Edenvale to Springs? (2)
- 1.3.3 Name the type of map represented in ANNEXURE A. (2)
- [20]**

QUESTION 2

- 2.1 Puseletso was invited to the University of Pretoria for an interview. She used the map in ANNEXURE B to get to her destination. Study the map in ANNEXURE B and answer the questions that follow.

- 2.1.1 How many provinces are represented on the map? (2)
- 2.1.2 Which neighbouring country is found on the western side of Limpopo? (2)
- 2.1.3 Identify the scale used in the map. (2)
- 2.1.4 Give a set of directions that Puseletso should use when travelling from Vryburg to Pretoria. (5)
- 2.1.5 Puseletso claimed that the actual distance that she will cover when travelling from Vryburg to Pretoria will be more than 450 km. Verify her claim by using the map and the scale to calculate the actual distance, as the crow flies. (6)

- 2.2
- Puseletso left Pretoria at 13:30.
 - She stopped twice, once for 10 minutes and again for 15 minutes to freshen up.
 - She arrived in Vryburg at 17:45.

- 2.2.1 Determine the average speed at which she was travelling, in km/h. Round-off your answer to the nearest whole number.

You may use the formula: $\text{Time} = \frac{\text{Distance}}{\text{Speed}}$ (6)

- 2.2.2 Name ONE disadvantage of driving during the day. (2)

[25]

QUESTION 3

- 3.1 Thami has a bakery, and he supplies wedding and birthday cakes to local supermarkets. He was requested to bake a birthday cake with the following dimensions and specifications:

Top Tier	Bottom Tier
<ul style="list-style-type: none"> Diameter is 20 cm Height is 15 cm It will be covered with icing, except at the bottom. 	<ul style="list-style-type: none"> Radius is 12,5 cm Height is 200 mm It will be covered with icing, except for the bottom of the cake and the top surface area on which the top tier will be resting.
<ul style="list-style-type: none"> Syrup will be used to stack the two tiers together. Tier refers to layers of cakes. The cake should be baked at 180°C. 	

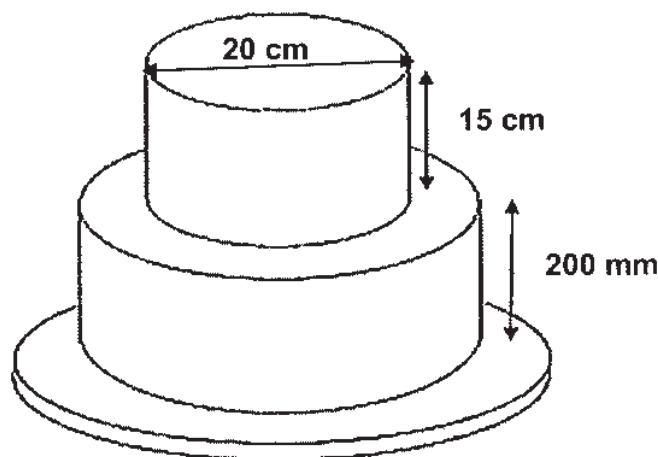

Study the information given above and answer the questions that follow.

- 3.1.1 Identify the shape of the top tier of the cake. (2)

- 3.1.2 Convert the temperature required to bake this cake to °F.

You may use the following formula: $^{\circ}\text{F} = (^{\circ}\text{C} \times \frac{9}{5}) + 32$ (2)

- 3.1.3 Calculate the volume of the top tier.

You may use the following formula: $\text{Volume} = \pi r^2 h$, where $\pi = 3,142$ (4)

3.1.4 Determine the surface area of the bottom tier that will be covered with icing. You

may use the following formula: **Surface area** = $\pi r^2 + 2\pi rh$, where $\pi = 3,142$ (8)

3.2 After icing the cake, Thami will put a ribbon around the top tier to decorate it and the ribbon will overlap by 2,2 cm. Determine the length of the ribbon.

You may use the following formula: **Circumference** = $2\pi r$, where $\pi = 3,142$ (4)

3.3 Thami started baking the cake at 19:48 and the cake was ready at the time displayed on the clock alongside due to loadshedding interruptions.

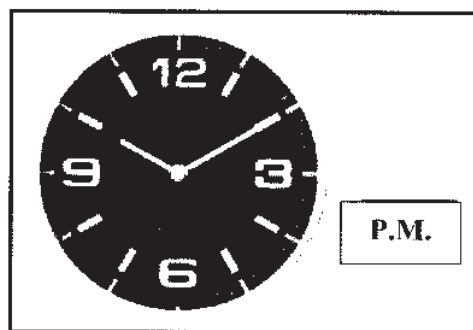

[Source: www.freepik.com]

3.3.1 Express the time displayed on the clock in 24-hour format. (2)

3.3.2 Determine the time taken for the cake to be baked. Express your answer in hours. (3)

3.3.3 Suggest an alternative source of power that can be used to beat loadshedding. (2)

[27]

QUESTION 4

4.1 Mr Kekana, the sports organiser at Cyprian High School planned a marathon for his soccer players. He shared the map shown in ANNEXURE C with the participants.

- Participants may choose to run a full marathon or a half marathon.
- The distance reflected on the map is in miles and the elevation above sea level is in feet.

Study the map in ANNEXURE C and answer the questions that follow.

NOTE:	
1 foot = 12 inches	1 mile = 5 280 feet
1 inch = 2,54 cm	1 foot = 30,48 cm

- 4.1.1 Give ONE advantage of completing a half marathon. (2)
- 4.1.2 Describe the trend of the graph from 14 miles to 26 miles. (4)
- 4.1.3 Determine the difference between the distances covered at the highest elevation and the end of a half marathon in metres. (7)

4.2 Mr Kekana took the soccer players to the local clinic for health screening before the marathon.

Study the growth chart in ANNEXURE D and the health status table below to answer the questions that follow.

BMI-for-Age Percentile Range	Weight Status
< 5 th percentile	Underweight
5 th to < 85 th percentile	Healthy
85 th to < 95 th percentile	Risk of overweight
≥ 95 th percentile	Overweight

- 4.2.1 How old is Njabulo, whose BMI of 19 kg/m² places him on the 50th percentile curve? (2)
- 4.2.2 (a) 16-year-old John with a weight of 67 kg and a height of 170 cm claims that his weight status is **healthy**. Verify his claim, by showing ALL calculations.

You may use the following formula: $BMI = \frac{Weight \text{ (in kg)}}{Height \text{ (in m)}^2}$ (6)

- (b) What advice, do you think, the nurse will give to a soccer player with a BMI-for-age percentile of 86? (2)

4.3 The following options of drinks and snacks will be served at the refreshment stations:

Drinks: Water (W), Juice (J) or Energy drinks (E)

Snacks: Banana (B) or Chocolate bar (C)

The tree diagram of the refreshments has been drawn below.

Study the tree diagram below and answer the questions that follow.

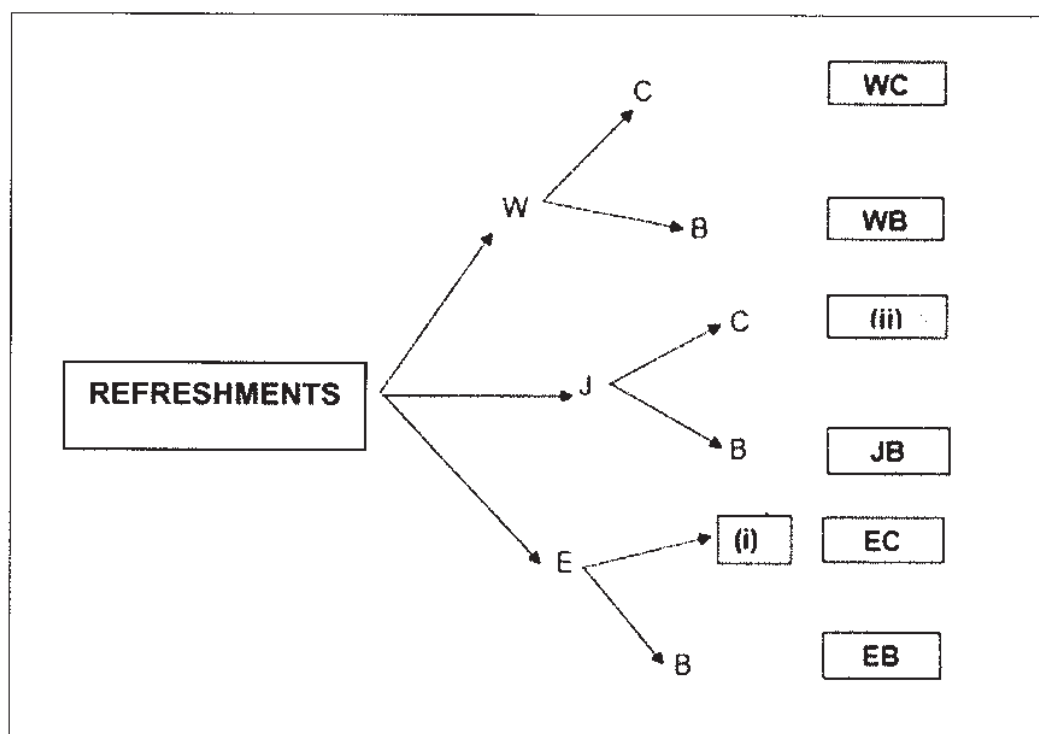

- 4.3.1 Complete the tree diagram by writing down the answers of (i) – (ii). (2)
- 4.3.2 Determine the probability of choosing a refreshment with juice. Express your answer as a decimal number. (3)

[28]

TOTAL: 100