

SA's Leading Past Year

Exam Paper Portal



You have Downloaded, yet Another Great Resource to assist you with your Studies 😊

Thank You for Supporting SA Exam Papers

Your Leading Past Year Exam Paper Resource Portal

Visit us @ www.saexampapers.co.za



**SA EXAM
PAPERS**
SA EXAM
PAPERS



basic education

Department:
Basic Education
REPUBLIC OF SOUTH AFRICA

**NATIONAL
SENIOR CERTIFICATE**

GRADE 12

TECHNICAL SCIENCES P2

NOVEMBER 2023

MARKS: 75

TIME: 1½ hours

This question paper consists of 9 pages and 4 data sheets.

INSTRUCTIONS AND INFORMATION

1. Write your centre number and examination number in the appropriate spaces on the ANSWER BOOK.
2. This question paper consists of SIX questions. Answer ALL the questions in the ANSWER BOOK.
3. Start EACH question on a NEW page in the ANSWER BOOK.
4. Number the answers correctly according to the numbering system used in this question paper.
5. Leave ONE line between two subquestions, e.g. between QUESTION 2.1 and QUESTION 2.2.
6. You may use a non-programmable calculator.
7. You are advised to use the attached DATA SHEETS.
8. Round off your FINAL numerical answers to a minimum of TWO decimal places.
9. Give brief motivations, discussions, etc. where required.
10. Write neatly and legibly.

QUESTION 1: MULTIPLE-CHOICE QUESTIONS

Various options are provided as possible answers to the following questions. Choose the answer and write only the letter (A–D) next to the question numbers (1.1 to 1.5) in the ANSWER BOOK, e.g. 1.6 D.

1.1 Consider the structural formula of the compound below.

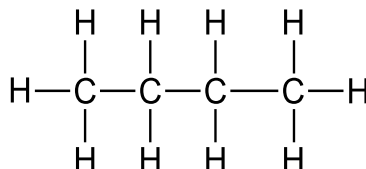

Which ONE of the following is the best description of the above compound?

	DESCRIPTION	HOMOLOGOUS SERIES
A	Saturated	Alkenes
B	Unsaturated	Alkanes
C	Saturated	Alkanes
D	Unsaturated	Alkynes

(2)

1.2 Consider the organic molecules below. **1** and **2** represent forces.

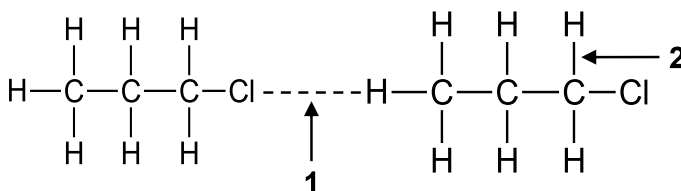

Which ONE of the following is correct for forces **1** and **2**?

	1	2
A	Interatomic	Intermolecular
B	Hydrogen bonds	London
C	Intermolecular	Interatomic
D	Dipole-dipole	London

(2)

1.3 Germanium is doped with an impurity having five valence electrons. How many free electrons are available as charge carriers?

A 1

B 2

C 5

D 4

(2)

1.4 An electrochemical cell is represented by the cell notation below.

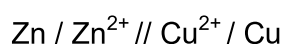

Which ONE of the following is the reducing agent?

A Cu

B Zn^{2+}

C Cu^{2+}

D Zn

(2)

1.5 In an electrolytic cell the anions will migrate to the ...

A cathode and undergo oxidation.

B anode and undergo oxidation.

C cathode and undergo reduction.

D anode and undergo reduction.

(2)

[10]

QUESTION 2 (Start on a new page.)

The table below represents organic molecules from different homologous series.

A	$\text{CH}_3\text{CH}_2\text{CH}_2\text{CH}_3$	B	$\left[\begin{array}{cc} \text{H} & \text{H} \\ & \\ -\text{C} & -\text{C}- \\ & \\ \text{H} & \text{H} \end{array} \right]_n$
C	$\begin{array}{cccccc} \text{H} & \text{H} & \text{H} & \text{H} & \text{H} & \text{H} \\ & & & & & \\ \text{H}-\text{C} & -\text{C} & -\text{C} & -\text{C} & -\text{C} & -\text{C}-\text{H} \\ & & & & & \\ \text{H} & \text{H} & \text{H} & \text{H} & \text{O} & \text{H} \\ & & & & & \\ & & & & \text{H} & \end{array}$	D	Hexan-1-ol
E	Propanone	F	$\begin{array}{ccc} \text{H} & \text{H} & \text{O} \\ & & \\ \text{H}-\text{C} & -\text{C} & -\text{C} \\ & & \backslash \\ \text{H} & \text{H} & \text{H} \end{array}$

- 2.1 Define the term *organic molecule*. (2)
- 2.2 Write down the letter(s) that represent(s) the following:
- 2.2.1 Polymer of ethene (1)
- 2.2.2 Positional isomers (2)
- 2.2.3 Alkane (1)
- 2.3 Draw the STRUCTURAL FORMULA of the following compounds:
- 2.3.1 **A** (2)
- 2.3.2 **D** (2)
- 2.4 Compounds **E** and **F** are functional isomers. Define the term *functional isomers*. (2)
- 2.5 Write down the IUPAC name of compound **F**. (2)
- 2.6 Write down the NAME of the homologous series of compound **E**. (1)

[15]

QUESTION 3 (Start on a new page.)

The table below shows the melting points of different organic compounds.

	COMPOUND	MELTING POINT (°C)
A	Propane	-188
B	Butane	-138
C	Propan-1-ol	-127

- 3.1 Define the term *melting point*. (2)
- 3.2 Explain the difference in the melting points of compounds **A** and **B** by referring to the TYPE OF INTERMOLECULAR FORCES, MOLECULAR STRUCTURE and the STRENGTH of intermolecular forces. (3)
- 3.3 Learners investigated the melting points of compounds **A** and **C**.
- 3.3.1 Is this a fair comparison? Explain the answer. (2)
- 3.3.2 Formulate an investigative question. (2)
- 3.3.3 Identify the independent variable. (1)
- 3.3.4 How will the viscosity of compound **A** compare to that of compound **C**? Write down only LOWER THAN, HIGHER THAN or EQUAL TO. (1)
- 3.3.5 Explain the answer to QUESTION 3.3.4. (2)
- [13]**

QUESTION 4 (Start on a new page.)

Consider the following reactions involving organic compounds.

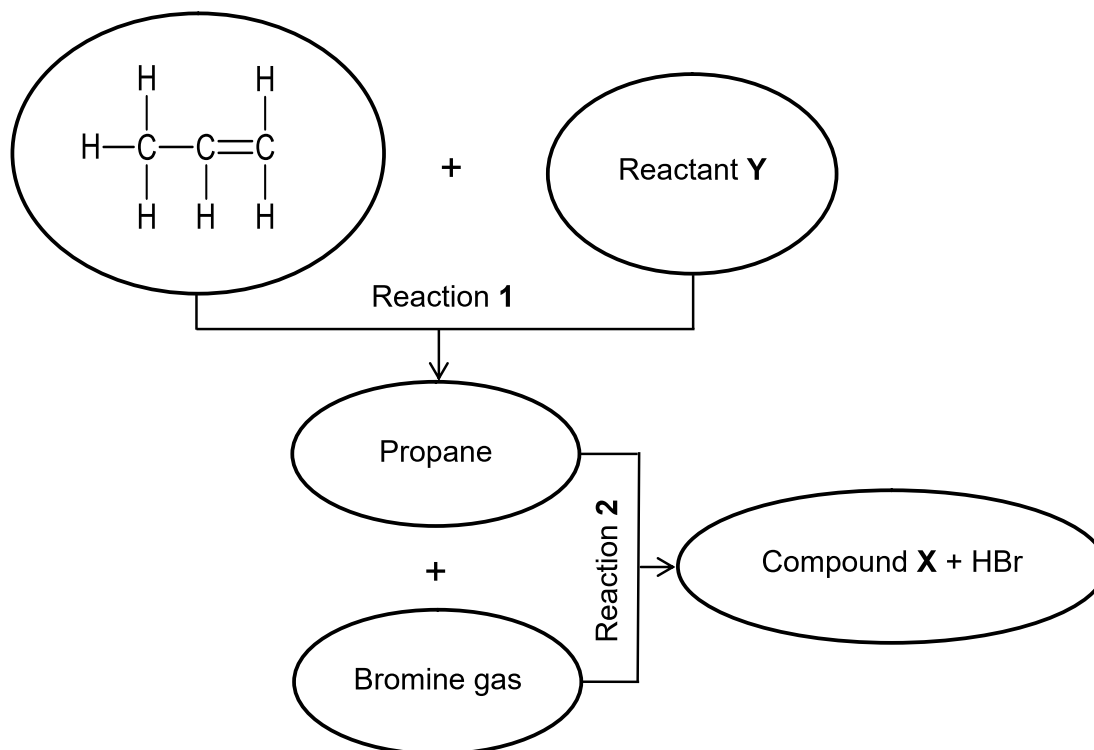

4.1 Name the TYPE of reaction represented by:

4.1.1 Reaction 1 (1)

4.1.2 Reaction 2 (1)

4.2 Write down a balanced chemical equation for reaction 1 by using MOLECULAR FORMULAE. (3)

4.3 Write down the IUPAC NAME or FORMULA of compound X. (2)

4.4 An alcohol is formed when compound X reacts with excess water.

Write down ONE reaction condition other than excess water. (1)

4.5 Define EACH of the following terms:

4.5.1 Macromolecule (2)

4.5.2 Polymerisation (2)

[12]

QUESTION 5 (Start on a new page.)

The diagram below shows an electrolytic cell used at an electroplating company to coat an iron bar with silver.

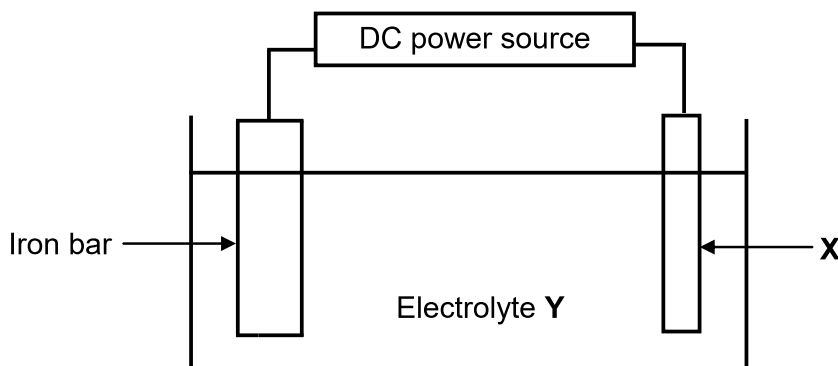

- 5.1 Define the term *electrolyte*. (2)
- 5.2 Write down the energy conversion that takes place in this cell. (2)
- 5.3 Is the reaction taking place in the cell spontaneous or nonspontaneous? Give a reason for the answer. (2)
- 5.4 Write down the:
- 5.4.1 Type of reaction taking place on the iron bar (1)
- 5.4.2 Half-reaction taking place at electrode X (2)
- 5.5 Apart from enhancing the appearance, write down TWO other reasons why the iron bar is electroplated with silver. (2)
- 5.6 Biodiesel as a replacement for petroleum diesel is becoming more important in South Africa.
- State TWO advantages of using biodiesel as an alternate energy source. (2)
- [13]**

QUESTION 6 (Start on a new page.)

A learner prepares an electrochemical cell by using silver and copper as electrodes. The MINIMUM voltage required to glow the bulb is 2,5 V. The cell operates under standard conditions.

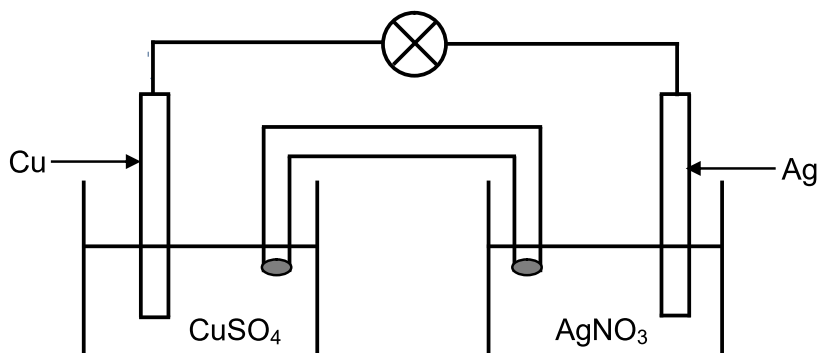

- 6.1 Define the term *oxidation*. (2)
- 6.2 Identify the negative electrode. (1)
- 6.3 In which direction will the electrons flow in the external circuit? Choose from **Ag to Cu** or **Cu to Ag**. (1)
- 6.4 What observation is made at the silver electrode after a while? (1)
- 6.5 Write down the cell notation for this cell. (3)
- 6.6 Use a calculation to determine whether the bulb will glow or not. (4)

[12]**TOTAL: 75**

**DATA FOR TECHNICAL SCIENCES GRADE 12
PAPER 2
GEGEWENS VIR TEGNIESE WETENSKAPPE GRAAD 12
VRAESTEL 2**

TABLE 1/TABEL 1: PHYSICAL CONSTANTS/FISIESE KONSTANTES

NAME/NAAM	SYMBOL/SIMBOOL	VALUE/WAARDE
Standard pressure <i>Standaarddruk</i>	p^θ	$1,01 \times 10^5 \text{ Pa}$
Standard temperature <i>Standaardtemperatuur</i>	T^θ	$0^\circ\text{C}/273 \text{ K}$

TABLE 2/TABEL 2: FORMULAE/FORMULES

Emf/Emk	$E^\theta_{\text{cell}} = E^\theta_{\text{cathode}} - E^\theta_{\text{anode}} \quad / \quad E^\theta_{\text{sel}} = E^\theta_{\text{katode}} - E^\theta_{\text{anode}}$ <i>or/of</i> $E^\theta_{\text{cell}} = E^\theta_{\text{reduction}} - E^\theta_{\text{oxidation}} \quad / \quad E^\theta_{\text{sel}} = E^\theta_{\text{reduksie}} - E^\theta_{\text{oksidasie}}$ <i>or/of</i> $E^\theta_{\text{cell}} = E^\theta_{\text{oxidising agent}} - E^\theta_{\text{reducing agent}} \quad / \quad E^\theta_{\text{sel}} = E^\theta_{\text{oksideermiddel}} - E^\theta_{\text{reduseermiddel}}$
---------	-----------------------------------------------------------------------------------------------------------------------------------------------------------------------------------------------------------------------------------------------------------------------------------------------------------------------------------------------------------------------------------------------------------------------------------------------------------------------------------------------------------------------------------------------------------------------------------------------------------------------------

TABLE 3: THE PERIODIC TABLE OF ELEMENTS
TABEL 3: DIE PERIODIEKE TABEL VAN ELEMENTE

KEY/SLEUTEL	1 (I)	2 (II)	3	4	5	6	7	8	9	10	11	12	13 (III)	14 (IV)	15 (V)	16 (VI)	17 (VII)	18 (VIII)																																																																		
Atomic number Atoomgetal	1 H 1,01	2 He 4,00	3 Li 6,94	4 Be 9,01	5 B 10,81	6 C 12,01	7 N 14,01	8 O 16,00	9 F 18,99	10 Ne 20,18	11 Na 22,99	12 Mg 24,31	13 Al 26,98	14 Si 28,09	15 P 30,97	16 S 32,06	17 Cl 35,45	18 Ar 39,95																																																																		
Electronegativity Elektronegatiwiteit	0,7	0,9	0,9	1,0	1,5	2,5	3,0	3,5	4,0	5,0	1,9	1,3	1,5	1,8	2,1	2,5	3,0	4,0																																																																		
Approximate relative atomic mass Benaderde relatiewe atoommassa	1	4	7	9	10	12	14	16	19	20	24	27	28	30	31	32	35	39																																																																		
Symbol Simbool	H	He	Li	Be	B	C	N	O	F	Ne	Na	Mg	Al	Si	P	S	Cl	Ar																																																																		
19 K 39,10	20 Ca 40,08	21 Sc 44,96	22 Ti 47,88	23 V 50,94	24 Cr 51,99	25 Mn 54,94	26 Fe 55,85	27 Co 58,93	28 Ni 58,71	29 Cu 63,55	30 Zn 65,38	31 Ga 69,72	32 Ge 72,64	33 As 74,92	34 Se 78,96	35 Br 79,90	36 Kr 83,80	37 Rb 85,47	38 Sr 87,62	39 Y 88,91	40 Zr 91,22	41 Nb 92,91	42 Mo 95,94	43 Tc 98,91	44 Ru 101,07	45 Rh 102,91	46 Pd 106,42	47 Ag 107,87	48 Cd 112,41	49 In 114,82	50 Sn 118,71	51 Sb 121,76	52 Te 127,60	53 I 126,91	54 Xe 131,29	55 Cs 132,91	56 Ba 137,33	57 La 138,91	58 Ce 140,12	59 Pr 140,91	60 Nd 144,24	61 Pm 144,91	62 Sm 150,36	63 Eu 151,96	64 Gd 157,25	65 Tb 158,93	66 Dy 162,50	67 Ho 164,93	68 Er 167,26	69 Tm 168,93	70 Yb 173,05	71 Lu 174,97	72 Hf 178,49	73 Ta 180,95	74 W 183,84	75 Re 186,21	76 Os 190,23	77 Ir 192,22	78 Pt 195,08	79 Au 196,97	80 Hg 200,59	81 Tl 204,38	82 Pb 207,2	83 Bi 208,98	84 Po 209	85 At 210	86 Rn 222	87 Fr 223	88 Ra 226	89 Ac	90 Th 232,04	91 Pa 231,04	92 U 238,03	93 Np 237,05	94 Pu 244,06	95 Am 243,06	96 Cm 247,07	97 Bk 247,07	98 Cf 251,08	99 Es 252,08	100 Fm 257,10	101 Md 258,10	102 No 259,10	103 Lr 262,11

TABLE 4A: STANDARD REDUCTION POTENTIALS
TABEL 4A: STANDAARD-REDUKSIEPOTENSIALE

Increasing strength of oxidising agents/Toenemende sterkte van oksideermiddels

Half-reactions/Halfreaksies		E ⁰ (V)
$F_2(g) + 2e^-$	$\rightleftharpoons 2F^-$	+ 2,87
$Co^{3+} + e^-$	$\rightleftharpoons Co^{2+}$	+ 1,81
$H_2O_2 + 2H^+ + 2e^-$	$\rightleftharpoons 2H_2O$	+ 1,77
$MnO_4^- + 8H^+ + 5e^-$	$\rightleftharpoons Mn^{2+} + 4H_2O$	+ 1,51
$Cl_2(g) + 2e^-$	$\rightleftharpoons 2Cl^-$	+ 1,36
$Cr_2O_7^{2-} + 14H^+ + 6e^-$	$\rightleftharpoons 2Cr^{3+} + 7H_2O$	+ 1,33
$O_2(g) + 4H^+ + 4e^-$	$\rightleftharpoons 2H_2O$	+ 1,23
$MnO_2 + 4H^+ + 2e^-$	$\rightleftharpoons Mn^{2+} + 2H_2O$	+ 1,23
$Pt^{2+} + 2e^-$	$\rightleftharpoons Pt$	+ 1,20
$Br_2(l) + 2e^-$	$\rightleftharpoons 2Br^-$	+ 1,07
$NO_3^- + 4H^+ + 3e^-$	$\rightleftharpoons NO(g) + 2H_2O$	+ 0,96
$Hg^{2+} + 2e^-$	$\rightleftharpoons Hg(l)$	+ 0,85
$Ag^+ + e^-$	$\rightleftharpoons Ag$	+ 0,80
$NO_3^- + 2H^+ + e^-$	$\rightleftharpoons NO_2(g) + H_2O$	+ 0,80
$Fe^{3+} + e^-$	$\rightleftharpoons Fe^{2+}$	+ 0,77
$O_2(g) + 2H^+ + 2e^-$	$\rightleftharpoons H_2O_2$	+ 0,68
$I_2 + 2e^-$	$\rightleftharpoons 2I^-$	+ 0,54
$Cu^+ + e^-$	$\rightleftharpoons Cu$	+ 0,52
$SO_2 + 4H^+ + 4e^-$	$\rightleftharpoons S + 2H_2O$	+ 0,45
$2H_2O + O_2 + 4e^-$	$\rightleftharpoons 4OH^-$	+ 0,40
$Cu^{2+} + 2e^-$	$\rightleftharpoons Cu$	+ 0,34
$SO_4^{2-} + 4H^+ + 2e^-$	$\rightleftharpoons SO_2(g) + 2H_2O$	+ 0,17
$Cu^{2+} + e^-$	$\rightleftharpoons Cu^+$	+ 0,16
$Sn^{4+} + 2e^-$	$\rightleftharpoons Sn^{2+}$	+ 0,15
$S + 2H^+ + 2e^-$	$\rightleftharpoons H_2S(g)$	+ 0,14
$2H^+ + 2e^-$	$\rightleftharpoons H_2(g)$	0,00
$Fe^{3+} + 3e^-$	$\rightleftharpoons Fe$	- 0,06
$Pb^{2+} + 2e^-$	$\rightleftharpoons Pb$	- 0,13
$Sn^{2+} + 2e^-$	$\rightleftharpoons Sn$	- 0,14
$Ni^{2+} + 2e^-$	$\rightleftharpoons Ni$	- 0,27
$Co^{2+} + 2e^-$	$\rightleftharpoons Co$	- 0,28
$Cd^{2+} + 2e^-$	$\rightleftharpoons Cd$	- 0,40
$Cr^{3+} + e^-$	$\rightleftharpoons Cr^{2+}$	- 0,41
$Fe^{2+} + 2e^-$	$\rightleftharpoons Fe$	- 0,44
$Cr^{3+} + 3e^-$	$\rightleftharpoons Cr$	- 0,74
$Zn^{2+} + 2e^-$	$\rightleftharpoons Zn$	- 0,76
$2H_2O + 2e^-$	$\rightleftharpoons H_2(g) + 2OH^-$	- 0,83
$Cr^{2+} + 2e^-$	$\rightleftharpoons Cr$	- 0,91
$Mn^{2+} + 2e^-$	$\rightleftharpoons Mn$	- 1,18
$Al^{3+} + 3e^-$	$\rightleftharpoons Al$	- 1,66
$Mg^{2+} + 2e^-$	$\rightleftharpoons Mg$	- 2,36
$Na^+ + e^-$	$\rightleftharpoons Na$	- 2,71
$Ca^{2+} + 2e^-$	$\rightleftharpoons Ca$	- 2,87
$Sr^{2+} + 2e^-$	$\rightleftharpoons Sr$	- 2,89
$Ba^{2+} + 2e^-$	$\rightleftharpoons Ba$	- 2,90
$Cs^+ + e^-$	$\rightleftharpoons Cs$	- 2,92
$K^+ + e^-$	$\rightleftharpoons K$	- 2,93
$Li^+ + e^-$	$\rightleftharpoons Li$	- 3,05

Increasing strength of reducing agents/Toenemende sterkte van reduseermiddels

TABLE 4B: STANDARD REDUCTION POTENTIALS
TABEL 4B: STANDAARD-REDUKSIEPOTENSIALE

Half-reactions/ <i>Halfreaksies</i>	E^{\ominus} (V)
$\text{Li}^+ + \text{e}^- \rightleftharpoons \text{Li}$	- 3,05
$\text{K}^+ + \text{e}^- \rightleftharpoons \text{K}$	- 2,93
$\text{Cs}^+ + \text{e}^- \rightleftharpoons \text{Cs}$	- 2,92
$\text{Ba}^{2+} + 2\text{e}^- \rightleftharpoons \text{Ba}$	- 2,90
$\text{Sr}^{2+} + 2\text{e}^- \rightleftharpoons \text{Sr}$	- 2,89
$\text{Ca}^{2+} + 2\text{e}^- \rightleftharpoons \text{Ca}$	- 2,87
$\text{Na}^+ + \text{e}^- \rightleftharpoons \text{Na}$	- 2,71
$\text{Mg}^{2+} + 2\text{e}^- \rightleftharpoons \text{Mg}$	- 2,36
$\text{Al}^{3+} + 3\text{e}^- \rightleftharpoons \text{Al}$	- 1,66
$\text{Mn}^{2+} + 2\text{e}^- \rightleftharpoons \text{Mn}$	- 1,18
$\text{Cr}^{2+} + 2\text{e}^- \rightleftharpoons \text{Cr}$	- 0,91
$2\text{H}_2\text{O} + 2\text{e}^- \rightleftharpoons \text{H}_2(\text{g}) + 2\text{OH}^-$	- 0,83
$\text{Zn}^{2+} + 2\text{e}^- \rightleftharpoons \text{Zn}$	- 0,76
$\text{Cr}^{3+} + 3\text{e}^- \rightleftharpoons \text{Cr}$	- 0,74
$\text{Fe}^{2+} + 2\text{e}^- \rightleftharpoons \text{Fe}$	- 0,44
$\text{Cr}^{3+} + \text{e}^- \rightleftharpoons \text{Cr}^{2+}$	- 0,41
$\text{Cd}^{2+} + 2\text{e}^- \rightleftharpoons \text{Cd}$	- 0,40
$\text{Co}^{2+} + 2\text{e}^- \rightleftharpoons \text{Co}$	- 0,28
$\text{Ni}^{2+} + 2\text{e}^- \rightleftharpoons \text{Ni}$	- 0,27
$\text{Sn}^{2+} + 2\text{e}^- \rightleftharpoons \text{Sn}$	- 0,14
$\text{Pb}^{2+} + 2\text{e}^- \rightleftharpoons \text{Pb}$	- 0,13
$\text{Fe}^{3+} + 3\text{e}^- \rightleftharpoons \text{Fe}$	- 0,06
$2\text{H}^+ + 2\text{e}^- \rightleftharpoons \text{H}_2(\text{g})$	0,00
$\text{S} + 2\text{H}^+ + 2\text{e}^- \rightleftharpoons \text{H}_2\text{S}(\text{g})$	+ 0,14
$\text{Sn}^{4+} + 2\text{e}^- \rightleftharpoons \text{Sn}^{2+}$	+ 0,15
$\text{Cu}^{2+} + \text{e}^- \rightleftharpoons \text{Cu}^+$	+ 0,16
$\text{SO}_4^{2-} + 4\text{H}^+ + 2\text{e}^- \rightleftharpoons \text{SO}_2(\text{g}) + 2\text{H}_2\text{O}$	+ 0,17
$\text{Cu}^{2+} + 2\text{e}^- \rightleftharpoons \text{Cu}$	+ 0,34
$2\text{H}_2\text{O} + \text{O}_2 + 4\text{e}^- \rightleftharpoons 4\text{OH}^-$	+ 0,40
$\text{SO}_2 + 4\text{H}^+ + 4\text{e}^- \rightleftharpoons \text{S} + 2\text{H}_2\text{O}$	+ 0,45
$\text{Cu}^+ + \text{e}^- \rightleftharpoons \text{Cu}$	+ 0,52
$\text{I}_2 + 2\text{e}^- \rightleftharpoons 2\text{I}^-$	+ 0,54
$\text{O}_2(\text{g}) + 2\text{H}^+ + 2\text{e}^- \rightleftharpoons \text{H}_2\text{O}_2$	+ 0,68
$\text{Fe}^{3+} + \text{e}^- \rightleftharpoons \text{Fe}^{2+}$	+ 0,77
$\text{NO}_3^- + 2\text{H}^+ + \text{e}^- \rightleftharpoons \text{NO}_2(\text{g}) + \text{H}_2\text{O}$	+ 0,80
$\text{Ag}^+ + \text{e}^- \rightleftharpoons \text{Ag}$	+ 0,80
$\text{Hg}^{2+} + 2\text{e}^- \rightleftharpoons \text{Hg}(\ell)$	+ 0,85
$\text{NO}_3^- + 4\text{H}^+ + 3\text{e}^- \rightleftharpoons \text{NO}(\text{g}) + 2\text{H}_2\text{O}$	+ 0,96
$\text{Br}_2(\ell) + 2\text{e}^- \rightleftharpoons 2\text{Br}^-$	+ 1,07
$\text{Pt}^{2+} + 2\text{e}^- \rightleftharpoons \text{Pt}$	+ 1,20
$\text{MnO}_2 + 4\text{H}^+ + 2\text{e}^- \rightleftharpoons \text{Mn}^{2+} + 2\text{H}_2\text{O}$	+ 1,23
$\text{O}_2(\text{g}) + 4\text{H}^+ + 4\text{e}^- \rightleftharpoons 2\text{H}_2\text{O}$	+ 1,23
$\text{Cr}_2\text{O}_7^{2-} + 14\text{H}^+ + 6\text{e}^- \rightleftharpoons 2\text{Cr}^{3+} + 7\text{H}_2\text{O}$	+ 1,33
$\text{Cl}_2(\text{g}) + 2\text{e}^- \rightleftharpoons 2\text{Cl}^-$	+ 1,36
$\text{MnO}_4^- + 8\text{H}^+ + 5\text{e}^- \rightleftharpoons \text{Mn}^{2+} + 4\text{H}_2\text{O}$	+ 1,51
$\text{H}_2\text{O}_2 + 2\text{H}^+ + 2\text{e}^- \rightleftharpoons 2\text{H}_2\text{O}$	+ 1,77
$\text{Co}^{3+} + \text{e}^- \rightleftharpoons \text{Co}^{2+}$	+ 1,81
$\text{F}_2(\text{g}) + 2\text{e}^- \rightleftharpoons 2\text{F}^-$	+ 2,87

Increasing strength of oxidising agents/*Toenemende sterkte van oksideermiddels*

Increasing strength of reducing agents/*Toenemende sterkte van reduseermiddels*