

# SA's Leading Past Year

## Exam Paper Portal



You have Downloaded, yet Another Great Resource to assist you with your Studies 😊

Thank You for Supporting SA Exam Papers

Your Leading Past Year Exam Paper Resource Portal

Visit us @ [www.saexampapers.co.za](http://www.saexampapers.co.za)



**SA EXAM  
PAPERS**  
SA EXAM  
PAPERS



# basic education

Department:  
Basic Education  
**REPUBLIC OF SOUTH AFRICA**

**NATIONAL  
SENIOR CERTIFICATE  
NASIONALE  
SENIOR SERTIFIKAAT**

**GRADE 12/GRAAD 12**

**TECHNICAL MATHEMATICS P2/TEGNIJSE WISKUNDE V2**

**NOVEMBER 2023**

**MARKING GUIDELINES/NASIENRIGLYNE**

**MARKS/PUNTE: 150**

<b>CODE/ KODE</b>	<b>EXPLANATION/VERDUIDELIKING</b>
<b>A</b>	Accuracy/Akkuraatheid
<b>AO</b>	Answer only/Slegs antwoord
<b>CA</b>	Consistent accuracy/Volgehoue akkuraatheid
<b>I</b>	Identity/Identiteit
<b>M</b>	Method/Metode
<b>NPR</b>	No penalty for rounding/Geen penalisering vir afronding nie
<b>NPU</b>	No penalty for omitting units/Geen penalisering vir eenhede weggelaat nie
<b>R</b>	Rounding/Afronding
<b>RE</b>	Reason/Rede
<b>S</b>	Simplification/Vereenvoudiging
<b>F</b>	Formula/Formule
<b>SF</b>	Substitution in correct formula/Vervanging in korrekte formule
<b>ST</b>	Statement/Bewering
<b>ST/RE</b>	Statement with reason/Bewering met rede

**These marking guidelines consist of 19 pages.  
Hierdie nasienriglyne bestaan uit 19 bladsye.**

**NOTE:**

- If a candidate answers a question **TWICE**, only mark the **FIRST** attempt.
- The method of Consistent Accuracy marking must be applied in all aspects of the marking guideline where applicable as indicated with the marking code **CA**.

**LET WEL:**

- Indien 'n kandidaat 'n vraag **TWEE** keer beantwoord, sien slegs die **EERSTE** poging na.
- Die metode van Volgehoue akkuraatheid-nasien moet waar moontlik tot alle aspekte van die nasienriglyne toegepas word soos aangedui deur die nasienkode **CA**.

**QUESTION/VRAAG 1**

1.1	$m_{DE} = \frac{y_D - y_E}{x_D - x_E}$ $= \frac{8 - (-4)}{-4 - 4}$ $= -\frac{3}{2}$	<p>✓ SF                      <b>A</b></p> <p>✓ gradient / gradiënt      <b>CA</b> (2)</p>
1.2	$\tan \alpha = m_{DE}$ $\alpha = \tan^{-1} \left( -\frac{3}{2} \right)$ <p>ref./verwys <math>\angle \approx 56,31^\circ</math></p> $\therefore \alpha = 123,69^\circ$	<p>✓ SF                      <b>CA</b></p> <p>✓ ref./ verwys <math>\angle</math>              <b>CA</b></p> <p>✓ value of / waarde van <math>\alpha</math>      <b>CA</b> (3)</p>



1.3	$m_{\text{parallel/ewewydig}} = -\frac{3}{2}$ $y - (-8) = -\frac{3}{2}(x - (-2)) \text{ OR/OF } -8 = -\frac{3}{2}(-2) + c$ $y = -\frac{3}{2}x - 3 - 8 \qquad c = -8 - 3$ $\therefore y = -\frac{3}{2}x - 11$ <p>Subst/ Vervang (-10; 5):</p> <p>LHS / LK = 5</p> $\text{RHS / RK} = -\frac{3}{2} \times (-10) - 11 = 4$ <p><math>\therefore</math> the point (-10; 5) does not lie on the line  <math>\therefore</math> die punt (-10; 5) lê dus nie op die lyn nie</p> <p style="text-align: center;"><b>OR/OF</b></p> $m_{\text{parallel/ewewydig}} = -\frac{3}{2}$ $m_{\text{point/punt\&F}} = \frac{-8 - 5}{-(-10)}$ $= \frac{-13}{8}$ <p><math>\therefore m_{\text{point/punt\&amp;F}} \neq m_{\text{parallel/ewewydig}}</math></p> <p><math>\therefore</math> the point (-10; 5) does not lie on the line  <math>\therefore</math> die punt (-10; 5) lê dus nie op die lyn nie</p>	<p>✓ gradient / gradiënt CA</p> <p>✓ equation / vergelyking CA</p> <p>✓ Subst/ Vervang (-10; 5) CA</p> <p>✓ conclusion / gevolgtrekking CA</p> <p style="text-align: center;"><b>OR/OF</b></p> <p>✓ gradient / gradiënt CA</p> <p>✓ SF A</p> <p>✓ gradient point &amp; F / gradiënt punt &amp; F CA</p> <p>✓ conclusion / gevolgtrekking CA (4)</p>
1.4	$EF = \sqrt{(x_F - x_E)^2 + (y_F - y_E)^2}$ $= \sqrt{(-2 - 4)^2 + (-8 - (-4))^2}$ $= \sqrt{52} = 2\sqrt{13}$ $DE = \sqrt{(-4 - 4)^2 + (8 - (-4))^2}$ $= 4\sqrt{13}$ $\text{Area of } \triangle DEF = \frac{1}{2} \times 2\sqrt{13} \times 4\sqrt{13}$ $= 52 \text{ square units / vierkante eenhede}$	<p>✓ SF A</p> <p>✓ length/ lengte EF CA</p> <p>✓ length/ lengte DE A</p> <p>✓ SF CA          ✓ area CA (5)</p>
<b>[14]</b>		

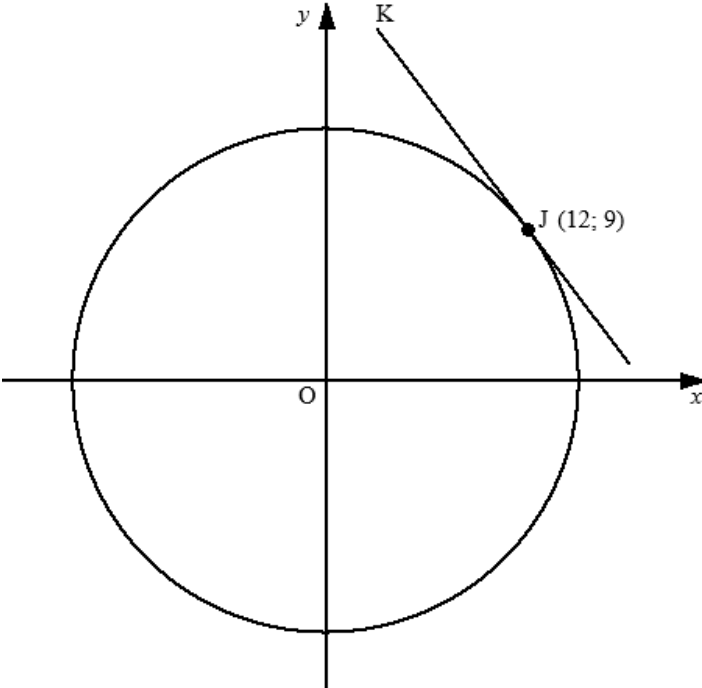

**QUESTION/VRAAG 2**

<p>2.1</p>		
<p>2.1.1</p>	$x^2 + y^2 = r^2$ $12^2 + 9^2 = r^2$ $r^2 = 225$ $\therefore x^2 + y^2 = 225$ <p style="text-align: center;"><b>OR/OF</b></p> $x^2 + y^2 = 12^2 + 9^2$ $= 225$	<p>✓ SF <span style="float: right;">A</span></p> <p>✓ equation/vergeljking <span style="float: right;">CA</span></p> <p style="text-align: center;"><b>OR/OF</b></p> <p>✓ SF <span style="float: right;">A</span></p> <p>✓ equation/vergeljking <span style="float: right;">CA</span> (2)</p>
<p>2.1.2</p>	<p>-1</p>	<p>✓ ST <span style="float: right;">A</span> (1)</p>
<p>2.1.3</p>	$m_{OJ} = \frac{9}{12} = \frac{3}{4}$ $m_{JK} = -\frac{4}{3}$ $y - 9 = -\frac{4}{3}(x - 12) \quad \text{OR/OF} \quad 9 = -\frac{4}{3}(12) + c$ $y = -\frac{4}{3}x + 16 + 9 \quad c = 9 + 16 = 25$ $\therefore y = -\frac{4}{3}x + 25$	<p>✓ gradient/gradjënt of/van OJ <span style="float: right;">A</span></p> <p>✓ gradient/gradjënt of/van JK <span style="float: right;">CA</span></p> <p>✓ substitution / vervanging <span style="float: right;">CA</span></p> <p>✓ equation/ vergeljking <span style="float: right;">CA</span></p>

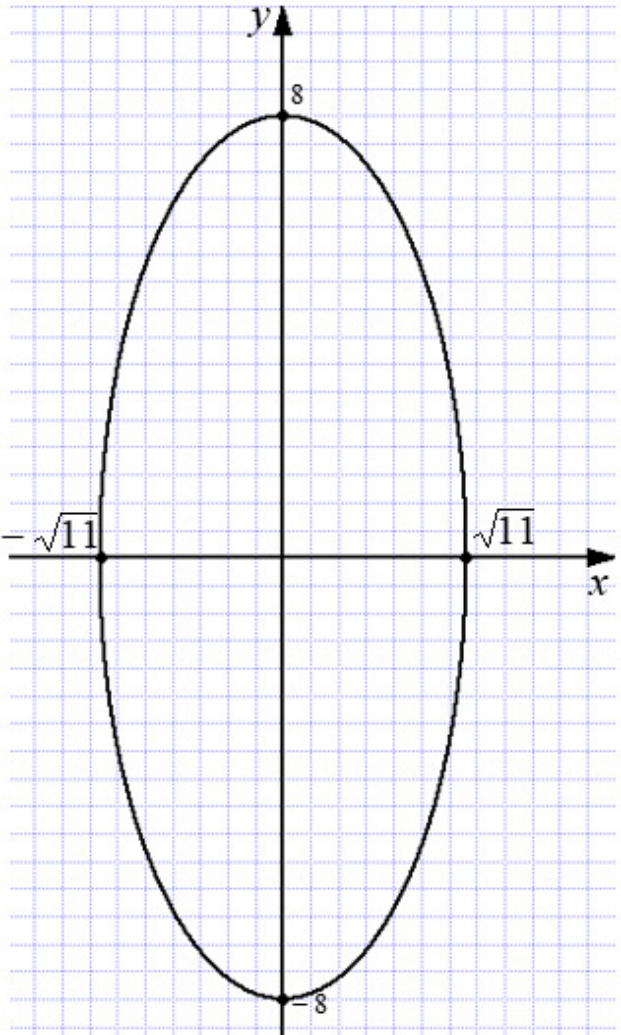

	<p style="text-align: center;"><b>OR/OF</b></p> $x \cdot x_1 + y \cdot y_1 = r^2$ $12x + 9y = 225$ $9y = -12x + 225$ $y = -\frac{4}{3}x + 25$	<p style="text-align: center;"><b>OR/OF</b></p> <p>✓ F <span style="float: right;">A</span></p> <p>✓ subst / vervang (12; 9) <span style="float: right;">A</span></p> <p>✓ subst / vervang <span style="float: right;">CA</span></p> <p>✓ equation / vergelyking <span style="float: right;">CA</span></p> <p style="text-align: right;">(4)</p>
<p>2.2.1</p>	$\frac{x^2}{(\sqrt{11})^2} + \frac{y^2}{8^2} = 1$	<p>✓ standard form/ standaardvorm <span style="float: right;">A</span></p> <p style="text-align: right;">(1)</p>
<p>2.2.2</p>		<p>✓ x and y –intercepts/ afsnitte <span style="float: right;">A</span></p> <p>✓ elliptical shape/ elliptiese vorm <span style="float: right;">CA</span></p> <p style="text-align: right;">(2)</p>
<b>[10]</b>		

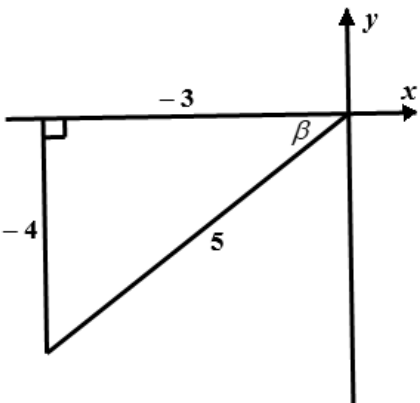

## QUESTION/VRAAG 3

3.1.1	$\sin(x - y)$ $= \sin(152,4^\circ - 24,8^\circ)$ $\approx 0,79$	✓ substitution / <i>vervanging</i> ✓ S	A CA (2)
3.1.2	$\frac{1}{2} \sec\left(\frac{x}{2} + 80^\circ\right)$ $= \frac{1}{2} \sec\left(\frac{152,4^\circ}{2} + 80^\circ\right)$ $= \frac{1}{2} \sec 156,2^\circ$ $= \frac{1}{2} \times \frac{1}{\cos 156,2^\circ}$ $\approx -0,55$	✓ substitution / <i>vervanging</i>          ✓ S	A          CA (2)
3.2.1	$\sin \beta = -\frac{4}{5}$ $\operatorname{cosec} \beta = -\frac{5}{4}$	✓ ratio / <i>verhouding</i>	CA (1)
3.2.2	 <p> <math display="block">x^2 + y^2 = r^2</math> <math display="block">x^2 + (-4)^2 = (5)^2</math> <math display="block">x^2 = 9</math> <math display="block">x = -3</math> <math display="block">\tan \beta + \cos \beta = \frac{-4}{-3} + \left(-\frac{3}{5}\right)</math> <math display="block">= \frac{11}{15}</math> </p>	✓ SF    ✓ value of/ <i>waarde van x</i>  ✓ tan ratio / <i>verh</i> ✓ cos ratio / <i>verh</i>  ✓ S	A    CA  CA  CA (5)



3.3	$\cos x = -\sin 56,7^\circ$ $\cos x = -0,835807361$ Ref. angle /verw hoek = $33,30^\circ$ $x = 180^\circ - 33,30^\circ$ or/of $x = 180^\circ + 33,30^\circ$ $\therefore x = 146,7^\circ$ or/of $x = 213,3^\circ$	$\checkmark$ S $\checkmark$ Ref. angle /verw hoek $\checkmark$ $146,7^\circ$ $\checkmark$ $213,3^\circ$	A CA CA CA (4)
			[14]

## QUESTION/VRAAG 4

4.1.1	$\frac{1}{\sin A}$	$\checkmark$ I	A (1)
4.1.2	$\cos A$	$\checkmark$ reduction /reduksie	A (1)
4.1.3	$-\operatorname{cosec} A$	$\checkmark$ reduction /reduksie	A (1)
4.2.	$\sin(180^\circ + A) \cdot \cot(360^\circ - A) \cdot \cos(2\pi - A) + \sin^2(360^\circ - A)$ $= (-\sin A) \cdot (-\cot A) \cdot \cos A + (-\sin A)^2$ $= \sin A \cdot \frac{\cos A}{\sin A} \cdot \cos A + \sin^2 A$ $= \cos^2 A + \sin^2 A$ $= 1$	$\checkmark$ $-\sin A$ $\checkmark$ $-\cot A$ $\checkmark$ $-\sin A$ or $\sin^2 A$ $\checkmark$ $\cos A$ $\checkmark$ cot identity/identiteit $\checkmark$ S $\checkmark$ answer/antwoord	A A A A A CA CA (7)
4.3.1	$\sec x(1 - \sec x)$	$\checkmark$ I	A (1)
4.3.2	$\frac{\operatorname{cosec} x - \operatorname{cosec} x \cdot \sec x}{\sec x - (\tan^2 x + 1)} = \cot x$ $\text{LHS} = \frac{\operatorname{cosec} x - \operatorname{cosec} x \cdot \sec x}{\sec x - (\tan^2 x + 1)}$ $= \frac{\operatorname{cosec} x(1 - \sec x)}{\sec x - \sec^2 x}$ $= \frac{\operatorname{cosec} x(1 - \sec x)}{\sec x(1 - \sec x)}$ $= \frac{1}{\sin x} \times \cos x$ $= \cot x \text{ OR/OF } \frac{1}{\tan x}$ $\therefore \text{LHS} = \text{RHS}$	$\checkmark$ factor/faktor (cosec x) $\checkmark$ I $\checkmark$ S $\checkmark$ I	A A CA A (4)
			[15]

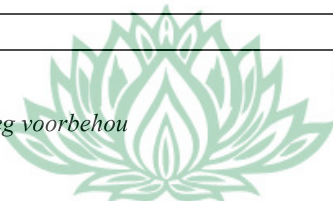



**QUESTION/VRAAG 5**

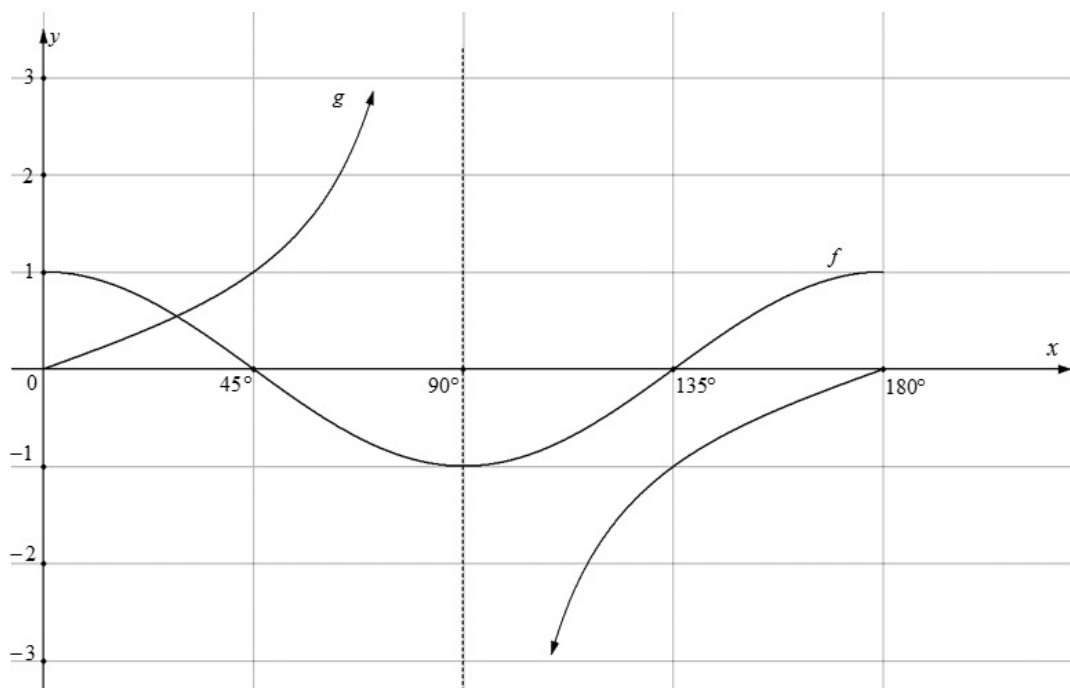

5.1.1	2	✓ value of/waarde van $a$	A (1)
5.1.2	$180^\circ$	✓ period /periode	A (1)
5.1.3	$\tan x = 1$ $x = 45^\circ$	✓ S ✓ value of/waarde van $x$	A A <b>AO: full marks/ volpunte</b> (2)
5.1.4	$y \in \mathbb{R}$ <b>OR/OF</b> $y \in (-\infty; \infty)$	✓ range /waardevers	A (1)
5.1.5	$x \in (45^\circ; 135^\circ)$ <b>OR/OF</b> $45^\circ < x < 135^\circ$	✓ critical values / kritiese waardes ✓ correct notation / korrekte notasie	A A (2)
5.2	$g(180^\circ) - f(180^\circ)$ $= 0 - 1$ $= -1$ $\tan 180^\circ - \cos 2(180^\circ)$ <b>OR/OF</b> $= 0 - 1$ $= -1$	✓ substitution / vervanging ✓ S	A CA (2)
5.3	$x \in (0^\circ; 90^\circ)$ <b>OR/OF</b> $0^\circ < x < 90^\circ$	✓ critical values / kritiese waardes ✓ correct notation / korrekte notasie	A A (2)
			<b>[11]</b>



## QUESTION/VRAAG 6

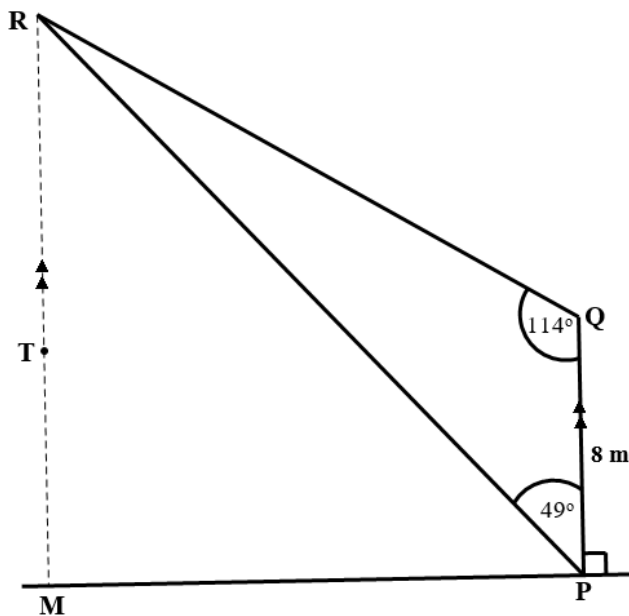

6.1	$\hat{Q}R\hat{P} = 17^\circ$ $\frac{PR}{\sin 114^\circ} = \frac{8}{\sin 17^\circ}$ $PR = \frac{8 \sin 114^\circ}{\sin 17^\circ}$ $\approx 25 \text{ m}$	✓ angle size /hoek grootte <b>A</b> ✓ substitution /vervanging <b>A</b> ✓ S <b>CA</b> ✓ length / lengte <b>CA</b> <b>(4)</b>
6.2	$\hat{R}P\hat{M} = 41^\circ$	✓ size /grootte <b>A</b> <b>(1)</b>
6.3	$\sin \hat{R}P\hat{M} = \frac{MR}{PR}$	✓ sin ratio /verh <b>A</b> <b>(1)</b>
6.4	$\sin 41^\circ = \frac{MR}{25}$ $MR = 25 \sin 41^\circ$ $= 16,4$ $MT = 16,4 - 5$ $= 11,4 \text{ m}$	✓ substitution /vervanging <b>CA</b> ✓ length/lengte of/van MR <b>CA</b>  ✓ length/lengte of/van MT <b>CA</b> <b>(3)</b>
		<b>[9]</b>

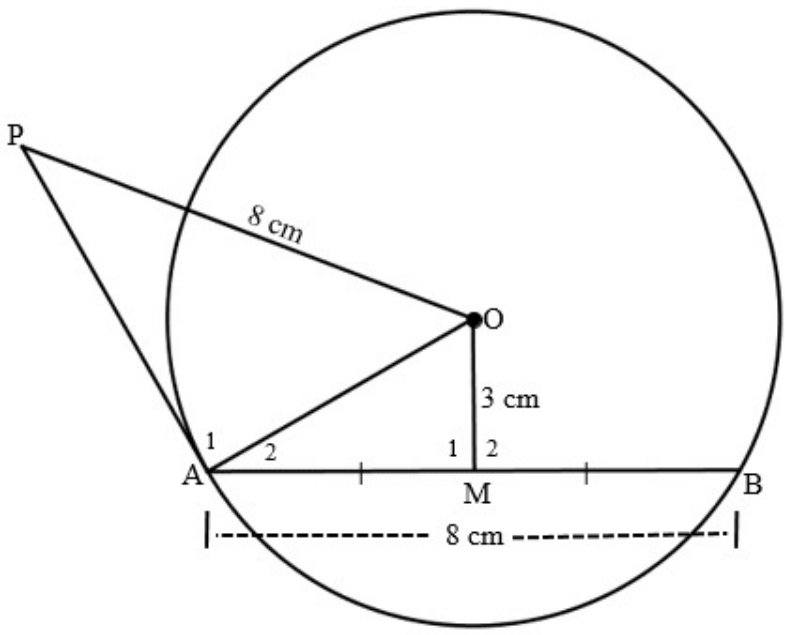

**QUESTION/VRAAG 7**

		
7.1	$\hat{M}_1 = 90^\circ$ (line from centre to midpoint of chord / lyn vanaf midpt na mdpt vankoord)	✓ ST ✓ RE A A (2)
7.2	(tan ⊥ rad / raaklyn ⊥ radius)	✓ RE A (1)
7.3	AM = 4 cm Midpoint <i>Middelpunt</i> AO = 5 cm (Pythagoras) $AP^2 + AO^2 = PO^2$ (Pythagoras) $AP^2 + 5^2 = 8^2$ $\therefore AP^2 = 64 - 25 = 39$ $\therefore AP \approx 6,24$ cm	✓ ST ✓ ST CA ✓ ST CA (3)
		[6]

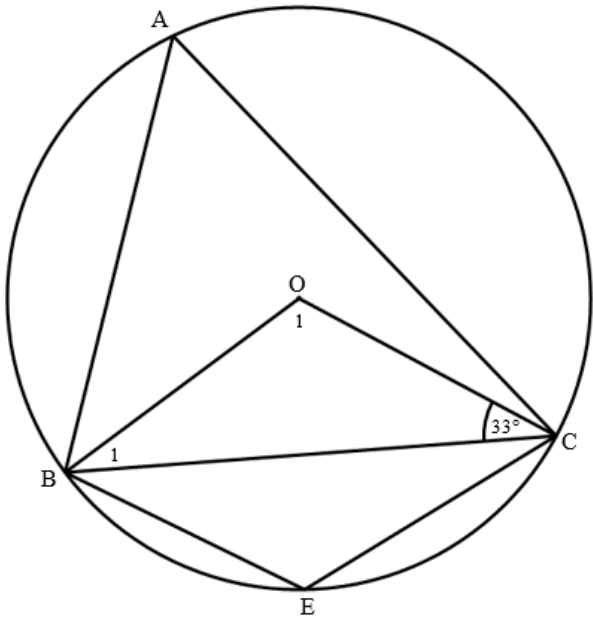

**QUESTION/VRAAG 8**

8.1			
8.1.1	$\hat{B}_1 = 33^\circ$ $\left( \begin{array}{l} \angle s \text{ opp} = \text{sides} / \\ \text{Le teenoor gelyke sye} \end{array} \right)$	✓ ST ✓ RE	A A (2)
8.1.2	$\hat{B}_1 + \hat{O}_1 + 33^\circ = 180^\circ$ $\left( \begin{array}{l} \text{int } \angle s \text{ of } \Delta / \\ \text{binne } \angle \text{ van } \Delta \end{array} \right)$ $\therefore \hat{O}_1 = 114^\circ$	✓ ST ✓ RE	CA A (2)
8.1.3	$\hat{A} = 57^\circ$ $\left( \begin{array}{l} \angle \text{ at centre} = 2 \times \angle \text{ at circumf} / \\ \text{midpts } \angle = 2 \times \text{omtreks} \angle \end{array} \right)$ $\therefore \hat{E} = 123^\circ$ $\left( \begin{array}{l} \text{opp } \angle s \text{ of a cyclic quad} / \\ \text{teenoorst } \angle \text{ e vankdvh} \end{array} \right)$	✓ ST ✓ RE  ✓ ST ✓ RE	CA A  CA A (4)



<p>8.2</p>		
<p>8.2.1</p>	<p><math>\hat{D} = 37^\circ</math> (tan - chord / raaklyn-koord)</p> <p><math>\hat{A} = 37^\circ</math> (tan - chord / raaklyn-koord) / (<math>\angle</math>s in same segment / <math>\angle</math>e in dies segment)</p> <p><math>\hat{C}_2 = 37^\circ</math> (alt <math>\angle</math>s; AC    DB / verw <math>\angle</math>e; AC    DB)</p> <p><math>\hat{B}_1 = 37^\circ</math> (alt <math>\angle</math>s; AC    DB / verw <math>\angle</math>e; AC    DB) / (<math>\angle</math>s in same segment / <math>\angle</math>e in dies segment)</p>	<p>✓ ST      A ✓ RE      A</p> <p>✓ ST/RE      A</p> <p>✓ ST      A ✓ RE      A</p> <p>✓ ST/RE      A (6)</p>
<p>8.2.2</p>	<p>In <math>\triangle AEC</math> and/en <math>\triangle BED</math>:</p> <p><math>\hat{A} = \hat{B} = 37^\circ</math> from/vanaf 8.2.1 <math>\hat{C} = \hat{D} = 37^\circ</math> from/vanaf 8.2.1</p> <p><math>\therefore \triangle AEC \parallel \triangle BED</math> (<math>\angle\angle\angle</math>) <b>OR/OF</b> <math>\hat{E}_1 = \hat{E}_3</math> (Vert opp <math>\angle</math>s / regoorst <math>\angle</math>e)</p> <p style="text-align: center;"><b>OR/OF</b></p> <p>In <math>\triangle AEC</math> and/en <math>\triangle DEB</math>:</p> <p><math>\hat{A} = \hat{D} = 37^\circ</math> from/vanaf 8.2.1 <math>\hat{C}_2 = \hat{B}_1 = 37^\circ</math> from/vanaf 8.2.1</p> <p><math>\therefore \triangle AEC \parallel \triangle DEB</math> (<math>\angle\angle\angle</math>) <b>OR/OF</b> <math>\hat{E}_1 = \hat{E}_3</math> (Vert opp <math>\angle</math>s / regoorst <math>\angle</math>e)</p>	<p>✓ both ST      CA</p> <p>✓ Concl/Gevlgr <b>OR/OF</b> Indicating 3<sup>rd</sup> pair / dui 3<sup>de</sup> paar      A</p> <p style="text-align: center;"><b>OR/OF</b></p> <p>✓ both ST      CA</p> <p>✓ Concl/ Gevlgr <b>OR/OF</b> Indicating 3<sup>rd</sup> pair / dui 3<sup>de</sup> paar      A (2)</p>

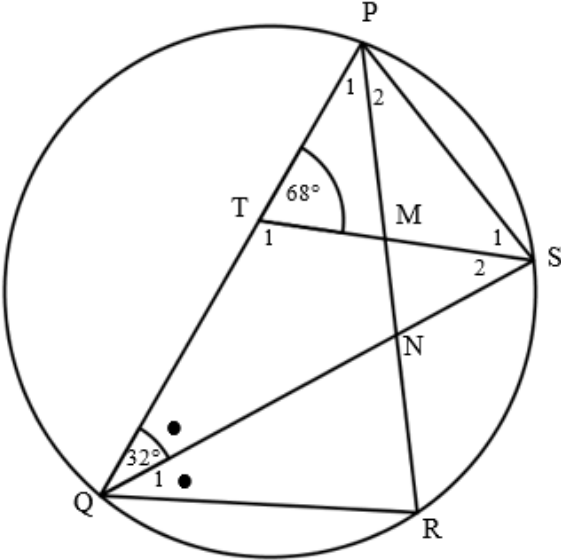

8.2.3.	$\therefore \frac{AE}{BE} = \frac{EC}{ED}$ $\therefore AE \times ED = EC \times BE$	✓ ST ✓ ST A A (2)
8.3		
8.3.1 a)	$\hat{Q}_1 = 32^\circ$ (SQ bisect $\angle$ / SQ halveer $\angle$ )	✓ ST A (1)
8.3.1 b)	$\hat{P}_2 = 32^\circ$ ( $\angle$ s in same segment / $\angle$ e in dies segment)	✓ ST ✓ RE A A (2)
8.3.2	$\hat{P} = 68^\circ$ ( $\angle$ s opp=sides / $\angle$ e teenoor =sye) $\therefore \hat{P}_1 = 36^\circ$ $\hat{S}_2 = 68^\circ - 32^\circ = 36^\circ$ (ext $\angle$ of $\Delta$ TQS / buite $\angle$ van $\Delta$ TQS) $\therefore \hat{P}_1 = \hat{S}_2$	✓ ST ✓ RE A A ✓ ST ✓ RE A A (5)
		[26]

## QUESTION/VRAAG 9

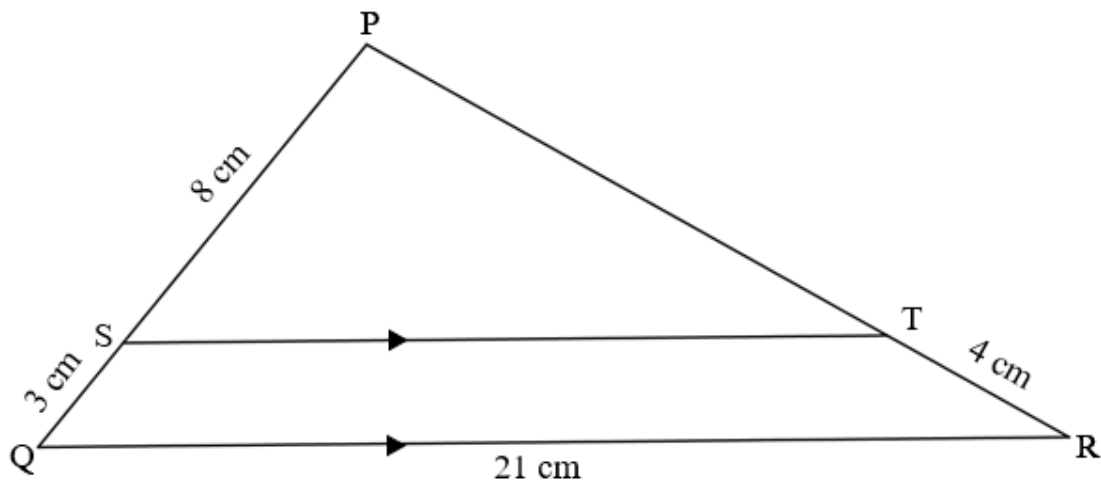

9.1	$\left( \begin{array}{l} \text{propth, } ST \parallel QR / \\ \text{ewer st, } ST \parallel QR \end{array} \right)$  <b>OR/OF</b> $\left( \begin{array}{l} \text{line } \parallel \text{ one side of } \Delta / \\ \text{lyn } \parallel \text{ aan een sy van } \Delta \end{array} \right)$	✓ RE	A (1)
9.2	$\frac{PT}{4} = \frac{8}{3}$  $\therefore PT = \frac{32}{3} \text{ cm OR/OF } \approx 10,67 \text{ cm}$	✓ Substitution /vervanging  ✓ ST	A  CA (2)
9.3	$\frac{ST}{QR} = \frac{PS}{PQ} \quad (\Delta PST \parallel \Delta PQR)$	✓ PQ ✓ RE	A A (2)
9.4	$\therefore \frac{ST}{21} = \frac{8}{11}$  $\therefore ST = \frac{168}{11} \text{ cm OR/OF } \approx 15,27 \text{ cm}$	✓ Substitution /vervanging  ✓ ST	A  CA (2)
			[7]



**QUESTION/VRAAG 10**

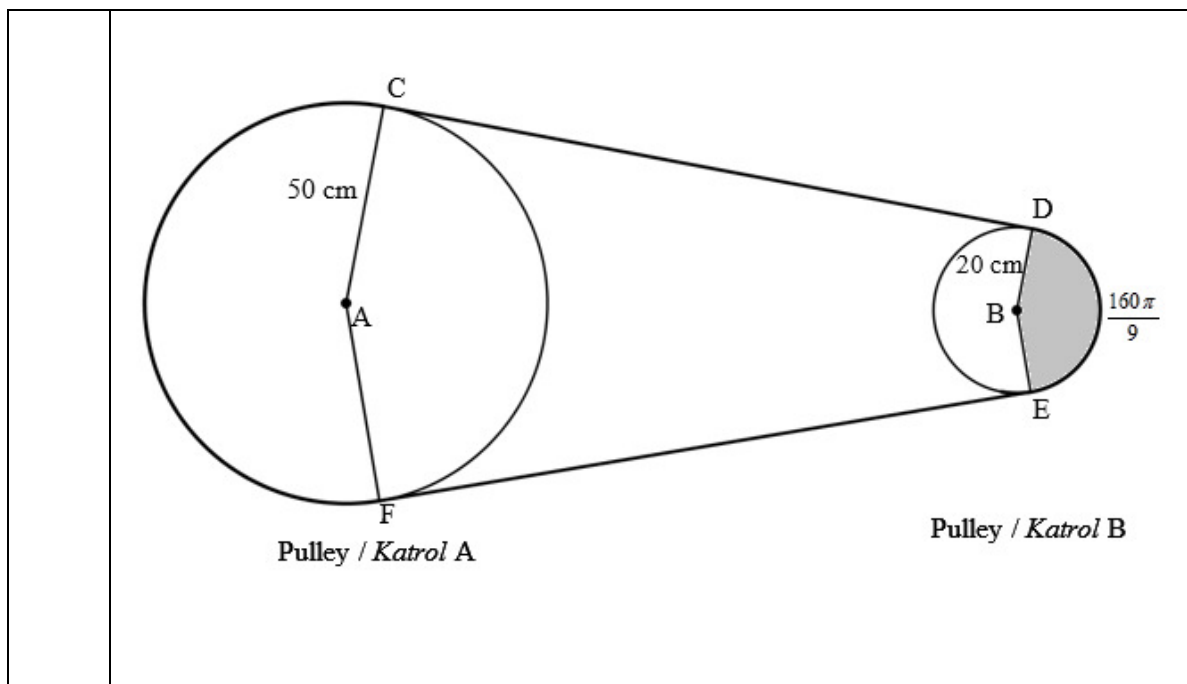

10.1.1	$\text{Reflex/ refleks } \hat{C}AF = \frac{5}{9} \times 360^\circ = 200^\circ$	$\checkmark \frac{5}{9} \times 360^\circ$	(1)
10.1.2	$200^\circ = 200^\circ \times \frac{\pi}{180^\circ} = \frac{10\pi}{9}$ <b>OR/OF</b> $\approx 3,49$ rad	$\checkmark$ angle/hoek in rad	A (1)
10.1.3	$s = r\theta$ $= 50 \times \frac{10\pi}{9}$ <b>OR/OF</b> $s = 50(200) \times \frac{\pi}{180^\circ}$ $= \frac{500\pi}{9}$ <b>OR/OF</b> $\approx 174,53$ cm	$\checkmark$ F $\checkmark$ SF $\checkmark$ arc length /booglengte	A CA CA (3)
10.1.4 a)	$v = \pi Dn$ $= \pi \times 100 \times 500$ $= 50\,000\pi$ <b>OR/OF</b> $\approx 157\,079,63$ cm/min <b>OR / OF</b> $\omega = 2\pi n$ $= 2\pi \times 500 = 1\,000\pi$ $v = \omega r$ $= 1\,000\pi \times 50$ $= 50\,000\pi$ <b>OR / OF</b> $\approx 157\,079,63$ cm/min	$\checkmark$ F $\checkmark$ SF $\checkmark$ circm vel /omtreksnld <b>OR/OF</b> $\checkmark$ F $\checkmark$ SF $\checkmark$ circm vel /omtreksnld	A CA CA A CA CA (3)





<p>10.1.4 b)</p>	$v = \frac{50\,000 \pi \text{ cm}}{1 \text{ min}} \times \frac{1 \text{ min}}{60 \text{ sec}} = \frac{2\,500 \pi}{3} \text{ cm/s}$ <p><math>v_B = v_A</math></p> $\therefore \pi \times 40 n = \frac{2\,500 \pi}{3}$ $\therefore n = \frac{125}{6} \text{ rev/s OR/OF } \approx 20,83 \text{ rev/s}$ <p style="text-align: center;"><b>OR/OF</b></p> <p><math>v_B = v_A</math></p> $\therefore \pi \times 40 n = 50\,000 \pi$ $\therefore n = 1\,250 \text{ rpm}$ $\therefore n = \frac{1\,250 \text{ rev}}{1 \text{ min}} \times \frac{1 \text{ min}}{60 \text{ sec}}$ $\therefore n = \frac{125}{6} \text{ rev/s OR/OF } \approx 20,83 \text{ rev/s}$	<p>✓ conversion /herleiding A</p> <p>✓ M (equating velocities) A</p> <p>✓ SF CA</p> <p>✓ value of n /waarde van n CA</p> <p style="text-align: center;"><b>OR/OF</b></p> <p>✓ M (equating velocities) A</p> <p>✓ SF CA</p> <p>✓ conversion /herleiding A</p> <p>✓ value of n /waarde van n CA</p> <p style="text-align: right;">(4)</p>
<p>10.1.5</p>	<p>Area of sector/ <math>= \frac{r s}{2}</math> Area van sektor</p> $= \frac{20 \times \frac{160\pi}{9}}{2}$ $= \frac{1600\pi}{9} \text{ cm}^2 \text{ OR/OF } \approx 558,51 \text{ cm}^2$ <p style="text-align: center;"><b>OR/OF</b></p> <p>Area of sector/ <math>= \frac{r^2 \theta}{2}</math> Area van sektor</p> $= \frac{20^2 \times \left(360^\circ \times \frac{4}{9}\right) \times \frac{\pi}{180^\circ}}{2}$ $= \frac{1600\pi}{9} \text{ cm}^2 \text{ OR/OF } \approx 558,51 \text{ cm}^2$ <p style="text-align: center;"><b>OR/OF</b></p> <p>Area of sector/ <math>= \frac{\theta}{360^\circ} \pi r^2</math> Area van sektor</p> $= \frac{360^\circ \times \frac{4}{9}}{360^\circ} \pi \times 20^2$ $= \frac{1600\pi}{9} \text{ cm}^2 \text{ OR/OF } \approx 558,51 \text{ cm}^2$	<p>✓ F A</p> <p>✓ SF A</p> <p>✓ area CA</p> <p style="text-align: center;"><b>OR/OF</b></p> <p>✓ F A</p> <p>✓ SF A</p> <p>✓ area CA</p> <p style="text-align: center;"><b>OR/OF</b></p> <p>✓ F A</p> <p>✓ SF A</p> <p>✓ area CA</p> <p style="text-align: right;">(3)</p>

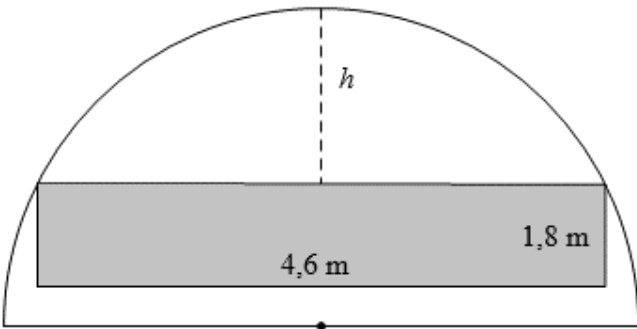

10.2		
10.2.1	$h = 1,8 + 0,72 = 2,52\text{m}$	✓ value of $h$ / waarde van $h$ <b>A</b> (1)
10.2.2	$4h^2 - 4dh + x^2 = 0$ $4h^2 - 4dh + x^2 = 0$ $4(2,52)^2 - 4d(2,52) + (4,6)^2 = 0$ $-10,08d = -46,5616$ $d \approx 4,62 \text{ m}$	✓ <b>F</b> <b>A</b> ✓ <b>SF</b> <b>CA</b>  ✓ <b>S</b> <b>CA</b> ✓ value of $d$ / waarde van $d$ <b>CA</b> (4)
		<b>[20]</b>



**QUESTION/VRAAG 11**

<p>11.1</p>		
<p>11.1.1</p>	$a = \frac{12}{6} = 2 \text{ cm}$	<p>✓ answer / antwoord      <b>A</b> (1)</p>
<p>11.1.2</p>	$h = \frac{6 + 7,22}{2} = 6,61 \text{ cm}$	<p>✓ <b>M</b>      <b>A</b> ✓ <b>ST</b>      <b>CA</b> (2)</p>
<p>11.1.3</p>	$\text{Area} = a \left( \frac{o_1 + o_n}{2} + o_2 + o_3 + \dots + o_{n-1} \right)$ $= 2 \left( \frac{8+2}{2} + 4 + 6 + 6,61 + 7,22 + 3,42 \right)$ $= 64,50 \text{ cm}^2$ <p style="text-align: center;"><b>OR / OF</b></p> $\text{Area} = a(m_1 + m_2 + m_3 + \dots + m_n)$ $= 2 \left( \frac{8+4}{2} + \frac{4+6}{2} + \frac{6+6,61}{2} + \frac{6,61+7,22}{2} + \frac{7,22+3,42}{2} + \frac{3,42+2}{2} \right)$ $= 64,50 \text{ cm}^2$	<p>✓ <b>F</b>      <b>A</b></p> <p>✓ <b>SF</b>      <b>CA</b></p> <p>✓ area      <b>A</b></p> <p style="text-align: center;"><b>OR / OF</b></p> <p>✓ <b>F</b>      <b>A</b></p> <p>✓ <b>SF</b>      <b>CA</b></p> <p>✓ area      <b>CA</b> (3)</p>

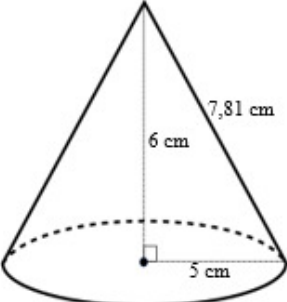

<p>11.2</p>	$\text{Volume}_{\text{Ball A}} = \frac{4}{3}\pi(11)^3$ $= \frac{5324}{3}\pi \text{ cm}^3$ $\therefore \text{Volume}_{\text{Ball B}} = \frac{1}{2} \times \frac{5324}{3}\pi$ $= \frac{2662}{3}\pi \text{ cm}^3$ $\therefore \frac{4}{3}\pi x^3 = \frac{2662}{3}\pi$ $x^3 = \frac{1331}{2} \text{ OR/OF } \approx 665,5$ $x = \sqrt[3]{\frac{1331}{2}} \text{ OR/OF } \quad x = \sqrt[3]{665,5}$ $\approx 8,73 \text{ cm}$	<p>✓ SF <span style="float:right">A</span></p> <p>✓ vol of ball A / vol van bal A <span style="float:right">CA</span></p> <p>✓ vol of ball B / vol van bal B <span style="float:right">CA</span></p> <p>✓ S <span style="float:right">CA</span></p> <p>✓ value of x / waarde van x <span style="float:right">CA</span></p> <p style="text-align:right">(5)</p>
<p>11.3</p>		
<p>11.3.1</p>	$S.A = \pi r^2 + \pi r l$ $= \pi(5)^2 + \pi(5)(7,81)$ $= \frac{1781}{2}\pi \text{ OR/OF } \approx 201,22 \text{ cm}$	<p>✓ SF <span style="float:right">A</span></p> <p>✓ surface/buite area <span style="float:right">CA</span></p> <p style="text-align:right">(2)</p>
<p>11.3.2</p>	$r_{\text{new/nuwe}} = 5 \times 1,2 = 6 \text{ cm}$ $h_{\text{new/nuwe}} = 6 \times 0,9 = 5,4 \text{ cm}$ $\therefore l_{\text{new/nuwe}} = \sqrt{5,4^2 + 6^2} \approx 8,07 \text{ cm}$ $\therefore SA_{\text{new/nuwe}} = \pi(6)^2 + \pi(6)(8,07)$ $= \frac{4221}{50}\pi \text{ OR/OF } \approx 265,21 \text{ cm}^2$ <p>∴ The new surface area is greater than the original area/Die nuwe buite-oppervlakte is groter as die oorspronklike oppervlakte.</p>	<p>✓ new/nuwe radius <span style="float:right">A</span></p> <p>✓ new height /nuwe hoogte <span style="float:right">A</span></p> <p>✓ new slant height / nuwe skuinshoogte <span style="float:right">CA</span></p> <p>✓ new/nuwe SA <span style="float:right">CA</span></p> <p>✓ concl / volgtr <span style="float:right">CA</span></p> <p style="text-align:right">(5)</p>
		<p>[18]</p>

TOTAL/TOTAAL: 150

