

SA's Leading Past Year

Exam Paper Portal



You have Downloaded, yet Another Great Resource to assist you with your Studies 😊

Thank You for Supporting SA Exam Papers

Your Leading Past Year Exam Paper Resource Portal

Visit us @ www.saexampapers.co.za



**SA EXAM
PAPERS**
SA EXAM
PAPERS



basic education

Department:
Basic Education
REPUBLIC OF SOUTH AFRICA

**NATIONAL
SENIOR CERTIFICATE**

GRADE 12

PHYSICAL SCIENCES: CHEMISTRY (P2)
NOVEMBER 2023

MARKS: 150

TIME: 3 hours

PHYSICAL SCIENCES: Paper 2



10842E

X10



This question paper consists of 16 pages and 4 data sheets.

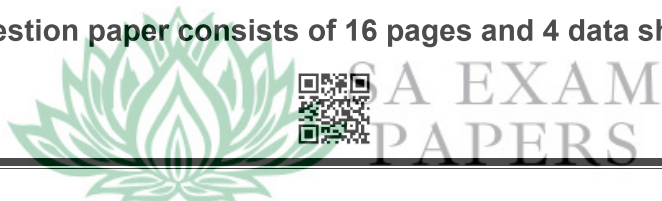

INSTRUCTIONS AND INFORMATION

1. Write your centre number and examination number in the appropriate spaces on the ANSWER BOOK.
2. This question paper consists of NINE questions. Answer ALL the questions in the ANSWER BOOK.
3. Start EACH question on a NEW page in the ANSWER BOOK.
4. Number the answers correctly according to the numbering system used in this question paper.
5. Leave ONE line between two subquestions, e.g. between QUESTION 2.1 and QUESTION 2.2.
6. You may use a non-programmable calculator.
7. You may use appropriate mathematical instruments.
8. Show ALL formulae and substitutions in ALL calculations.
9. Round off your FINAL numerical answers to a minimum of TWO decimal places.
10. Give brief motivations, discussions, etc. where required.
11. You are advised to use the attached DATA SHEETS.
12. Write neatly and legibly.

QUESTION 1: MULTIPLE-CHOICE QUESTIONS

Various options are provided as possible answers to the following questions. Each question has only ONE correct answer. Choose the answer and write only the letter (A–D) next to the question numbers (1.1 to 1.10) in the ANSWER BOOK, e.g. 1.11 E.

- 1.1 Which ONE of the following represents a straight chain SATURATED hydrocarbon?
- A C_5H_8
- B C_5H_{10}
- C C_6H_{12}
- D C_6H_{14} (2)
- 1.2 Which ONE of the following is a SECONDARY alcohol?
- A $C(CH_3)_3OH$
- B $CH_3(CH_2)_3OH$
- C $CH_3(CH_2)_2CHO$
- D $CH_3CH_2CH(OH)CH_3$ (2)
- 1.3 Which ONE of the following is a HYDROLYSIS reaction?
- A $CH_3CH_2Br + H_2O \rightarrow CH_3CH_2OH + HBr$
- B $CH_3CH_2OH + HBr \rightarrow CH_3CH_2Br + H_2O$
- C $CH_2=CH_2 + H_2O \rightarrow CH_3CH_2OH$
- D $CH_2=CH_2 + H_2 \rightarrow CH_3CH_3$ (2)

1.4 Hydrochloric acid reacts with EXCESS zinc:

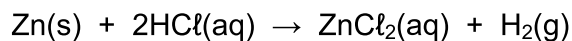

Different reaction conditions are shown in the diagrams below. The mass of zinc used is the same in both test tubes.

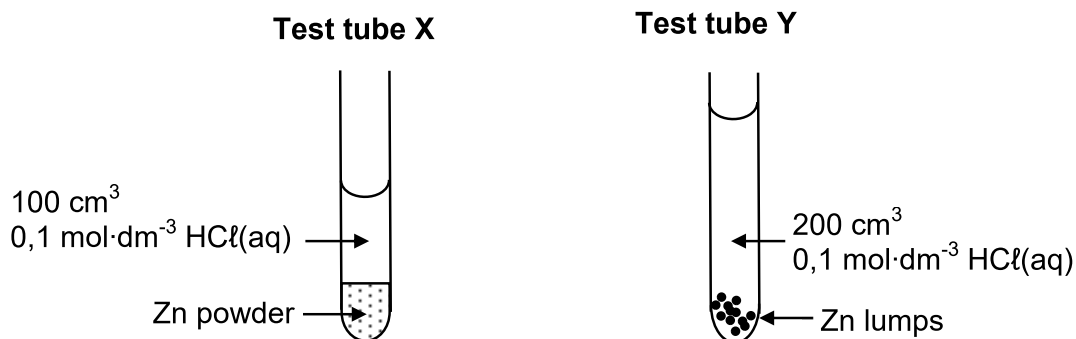

How will the INITIAL rate of reaction and FINAL VOLUME of H₂(g) produced in test tube Y compare with that in test tube X?

	INITIAL RATE OF REACTION IN Y	FINAL VOLUME OF H ₂ (G) IN Y
A	Higher	Equal
B	Lower	More
C	Lower	Equal
D	Higher	More

(2)

- 1.5 The diagram below represents a mixture of $\text{NO}_2(\text{g})$ and $\text{N}_2\text{O}_4(\text{g})$ molecules at equilibrium in a 1 dm^3 container at $T \text{ }^\circ\text{C}$.

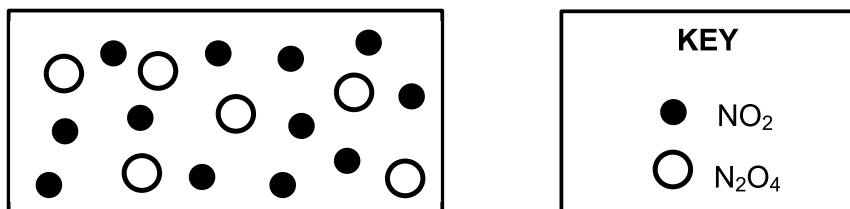

The balanced equation for this reaction is:

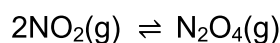

Which ONE of the following is TRUE for the value of the equilibrium constant, K_c , for the reaction at $T \text{ }^\circ\text{C}$?

- A $K_c = 24$
- B $K_c > 1$
- C $K_c = 1$
- D $0 < K_c < 1$ (2)
- 1.6 A reaction is at equilibrium in a closed container according to the following balanced equation:

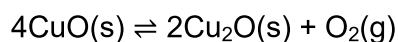

The volume of the container is now increased while the temperature remains constant. A new equilibrium is reached.

Which ONE of the following combinations is CORRECT for the new equilibrium?

	CONCENTRATION OF O_2	NUMBER of MOLES OF O_2	EQUILIBRIUM CONSTANT (K_c)
A	Decreases	Remains the same	Increases
B	Remains the same	Decreases	Remains the same
C	Remains the same	Increases	Remains the same
D	Decreases	Increases	Remains the same

(2)

- 1.7 Nitric acid, $\text{HNO}_3(\text{aq})$, and ethanoic acid, $\text{CH}_3\text{COOH}(\text{aq})$, of equal volumes and concentrations are compared.

Consider the following statements regarding these solutions:

- (i) They have different pH values.
- (ii) Both have the same electrical conductivity.
- (iii) Both solutions require the same number of moles of $\text{KOH}(\text{aq})$ for complete neutralisation.

Which of the above statement(s) is/are TRUE?

- A (i) only
 - B (i) and (ii) only
 - C (i) and (iii) only
 - D (ii) and (iii) only (2)
- 1.8 The apparatus in the diagram below is used for the titration between $\text{HCl}(\text{aq})$ and $\text{KOH}(\text{aq})$.

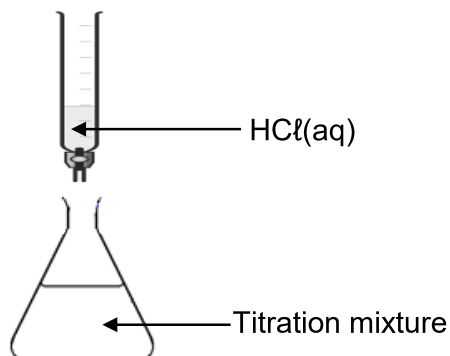

In a titration, the learner accidentally exceeds the endpoint. Which ONE of the following will be TRUE for the titration mixture?

- A $[\text{H}^+] > [\text{OH}^-]$ and $\text{pH} < 7$
- B $[\text{H}^+] < [\text{OH}^-]$ and $\text{pH} < 7$
- C $[\text{H}^+] < [\text{OH}^-]$ and $\text{pH} > 7$
- D $[\text{H}^+] > [\text{OH}^-]$ and $\text{pH} > 7$ (2)

- 1.9 The following hypothetical standard reduction potentials relate to a galvanic cell:

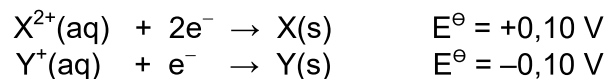

Consider the following statements for this galvanic cell:

- (i) The emf of the cell is 0,20 V under standard conditions.
- (ii) Electrode **Y** is the anode.
- (iii) **X** is oxidised.

Which of the above statement(s) is/are TRUE for this galvanic cell?

- A (i) only
 - B (i) and (ii) only
 - C (i) and (iii) only
 - D (ii) and (iii) only (2)
- 1.10 Which ONE of the half-reactions below will be the MAIN reaction at the ANODE during the electrolysis of CONCENTRATED $\text{CuCl}_2(\text{aq})$?

- A $\text{Cu}^{2+}(\text{aq}) + 2e^{-} \rightarrow \text{Cu}(\text{s})$
- B $2\text{H}_2\text{O}(\ell) + 2e^{-} \rightarrow \text{H}_2(\text{g}) + 2\text{OH}^{-}(\text{aq})$
- C $2\text{H}_2\text{O}(\ell) \rightarrow \text{O}_2(\text{g}) + 4\text{H}^{+}(\text{aq}) + 4e^{-}$
- D $2\text{Cl}^{-}(\text{aq}) \rightarrow \text{Cl}_2(\text{g}) + 2e^{-}$ (2)

[20]

QUESTION 2 (Start on a new page.)

The letters **A** to **H** in the table below represent eight organic compounds.

A	Heptanoic acid	B	$\text{CH}_3(\text{CH}_2)_3\text{COOCH}_3$
C	4-ethyl-3,3-difluorohexane	D	Hexanoic acid
E	$\begin{array}{c} \text{CH}_2 \\ \\ \text{CH} - \text{C} - \text{CH}_3 \\ \\ \text{CH}_3 \end{array}$	F	$\begin{array}{c} \text{O} \\ \\ \text{CH}_3 - \text{CH} - \text{C} - \text{CH}_2 - \text{CH}_3 \\ \\ \text{CH}_3 \end{array}$
G	$\begin{array}{c} \text{CH}_3 \\ \\ \text{CH}_3 - \text{C} - \text{CH}_2 - \text{CH}_3 \\ \\ \text{C} = \text{O} \\ \\ \text{H} - \text{O} \end{array}$	H	$\begin{array}{cccc} \text{H} & \text{H} & \text{O} & \text{H} \\ & & & \\ \text{H} - \text{C} & - \text{C} & - \text{C} & - \text{C} - \text{H} \\ & & & \\ \text{H} & \text{H} & & \text{H} \end{array}$

- 2.1 Define the term *organic compound*. (1)
- 2.2 Write down the IUPAC name of compound:
- 2.2.1 **E** (2)
- 2.2.2 **H** (2)
- 2.3 Write down the:
- 2.3.1 STRUCTURAL formula of compound **B** (2)
- 2.3.2 STRUCTURAL formula of compound **C** (3)
- 2.3.3 General formula of the homologous series to which compound **E** belongs (1)
- 2.3.4 STRUCTURAL formula of the FUNCTIONAL group of compound **F** (1)
- 2.3.5 IUPAC name of the alcohol needed to produce compound **B** (2)
- 2.4 Write down the letter(s) of the compound(s) that:
- 2.4.1 Is a FUNCTIONAL isomer of compound **G** (1)
- 2.4.2 Are CHAIN isomers of each other (1)
- [16]**

QUESTION 3 (Start on a new page.)

The relationship between boiling point and the molecular mass of aldehydes, carboxylic acids and primary alcohols is investigated. Curves **P**, **R** and **S** are obtained. All compounds used are straight chain molecules.

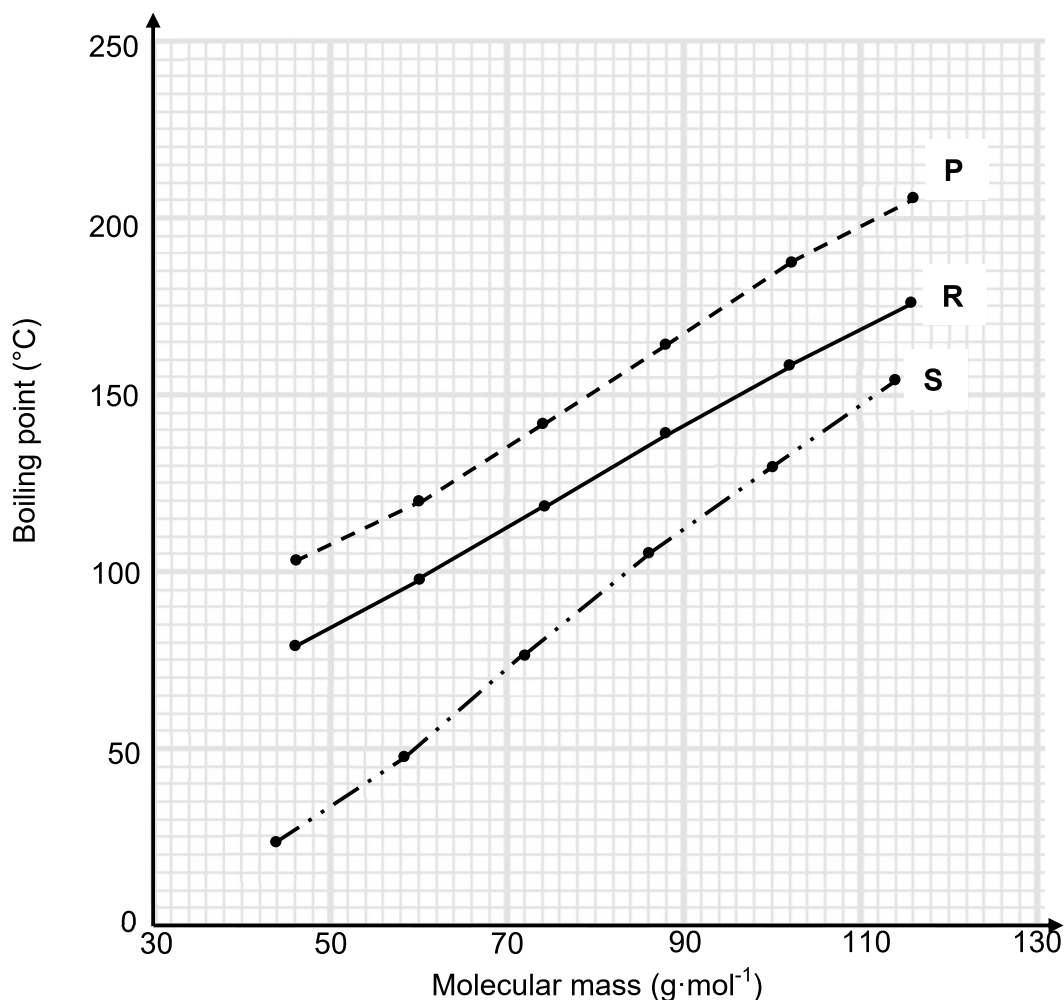
GRAPH OF BOILING POINT VERSUS MOLECULAR MASS

- 3.1 Define the term *boiling point*. (2)
- 3.2 Write down the conclusion that can be made for curve **P**. (2)
- 3.3 Explain the answer to QUESTION 3.2 in terms of the structures of the compounds. (2)
- 3.4 Curve **R** represents the alcohols.
- 3.4.1 Which homologous series is represented by curve **S**? (1)
- 3.4.2 Explain the answer to QUESTION 3.4.1 by referring to the strength of intermolecular forces. (2)

3.5 For curve **R**, write down the:

3.5.1 Molecular mass of the compound with a boiling point of 97 °C (1)

3.5.2 IUPAC name of the compound in QUESTION 3.5.1 (2)

3.6 Two compounds, **A** and **B**, used in this investigation have a molecular mass of $74 \text{ g}\cdot\text{mol}^{-1}$. **A** has a boiling point of 118 °C and **B** a boiling point of 142 °C. Explain the difference in these boiling points by referring to the structures of these compounds.

(3)
[15]

QUESTION 4 (Start on a new page.)

4.1 Consider the cracking reaction below.

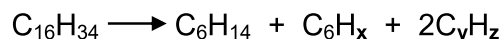
4.1.1 Define *cracking*. (2)4.1.2 Write down the values represented by **x**, **y** and **z** in the equation above. (3)Compound C_6H_{14} undergoes complete combustion.

4.1.3 Using MOLECULAR FORMULAE, write down the balanced equation for this reaction. (3)

4.2 Consider the equations for reactions I to III below.

A and **B** represent organic compounds that are POSITIONAL ISOMERS. **X** is an inorganic product.

I	$\text{CH}_3\text{CH}_2\text{CHCHCH}_3 + \text{HCl} \rightarrow \text{A} + \text{B}$
II	$\text{A} \xrightarrow[\Delta]{\text{H}_2\text{O}} \text{CH}_3\text{CH}_2\text{CH}_2\text{CH}(\text{OH})\text{CH}_3 + \text{X}$
III	$\text{CH}_3\text{CH}_2\text{CH}_2\text{CH}(\text{OH})\text{CH}_3 \longrightarrow \text{CH}_3\text{CH}_2\text{CHCHCH}_3 + \text{H}_2\text{O}$

Write down the:

4.2.1 Definition of *positional isomers* (2)

4.2.2 Type of reaction represented by reaction I (1)

4.2.3 STRUCTURAL formula of compound **B** (3)4.2.4 Formula of **X** (1)

4.2.5 Inorganic reagent for reaction III (1)

Compound **A** can be converted directly to the organic product of reaction III.

4.2.6 Besides heat, write down the reaction condition needed for this conversion. (1)

4.2.7 Write down TWO terms that describe this type of reaction. (2)

[19]

QUESTION 5 (Start on a new page.)

The reaction between EXCESS dilute hydrochloric acid and sodium thiosulphate is used to investigate factors that influence reaction rate.



The concentration of $\text{HCl}(\text{aq})$ used is $1 \text{ mol}\cdot\text{dm}^{-3}$. The same volume of $\text{HCl}(\text{aq})$ is used in each run.

The time taken for the cross on the paper under the flask to become invisible is measured.

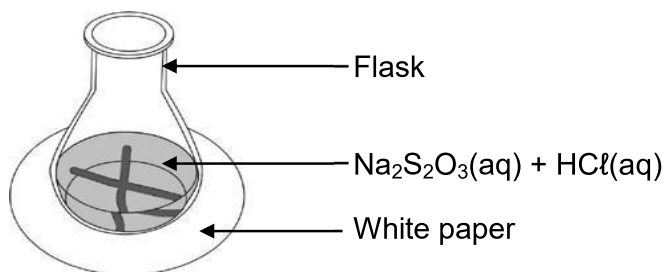

The table below summarises the reaction conditions and results of the experiment.

RUN	VOLUME $\text{Na}_2\text{S}_2\text{O}_3(\text{aq})$ (cm^3)	VOLUME $\text{H}_2\text{O}(\ell)$ ADDED (cm^3)	CONCENTRATION $\text{Na}_2\text{S}_2\text{O}_3(\text{aq})$ ($\text{mol}\cdot\text{dm}^{-3}$)	TIME (s)
1	50	0	0,13	20,4
2	40	10	0,10	26,7
3	30	20	P	33,3

5.1 Define *reaction rate*. (2)

5.2 Write down the independent variable for this investigation. (1)

5.3 Calculate the value of **P** in the table. (3)

5.4 When 0,21 g of sulphur has formed in Run **1**, the cross becomes invisible.

Calculate the average reaction rate with respect to sodium thiosulphate, $\text{Na}_2\text{S}_2\text{O}_3(\text{aq})$, in $\text{g}\cdot\text{s}^{-1}$. (5)

Another investigation is performed at different temperatures.

5.5 Sketch the Maxwell-Boltzmann distribution curve for the reaction at 20°C . Label this curve as **A**. On the same set of axis, draw the curve that will be obtained at 35°C and label it as **B**. (4)

5.6 Explain the effect of temperature on reaction rate in terms of the collision theory. (4)

[19]

QUESTION 6 (Start on a new page.)

Consider the following hypothetical reaction reaching equilibrium in a 4 dm³ closed container at 150 °C.

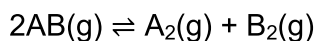

The graph below shows the changes in the amounts of reactants and products over time.

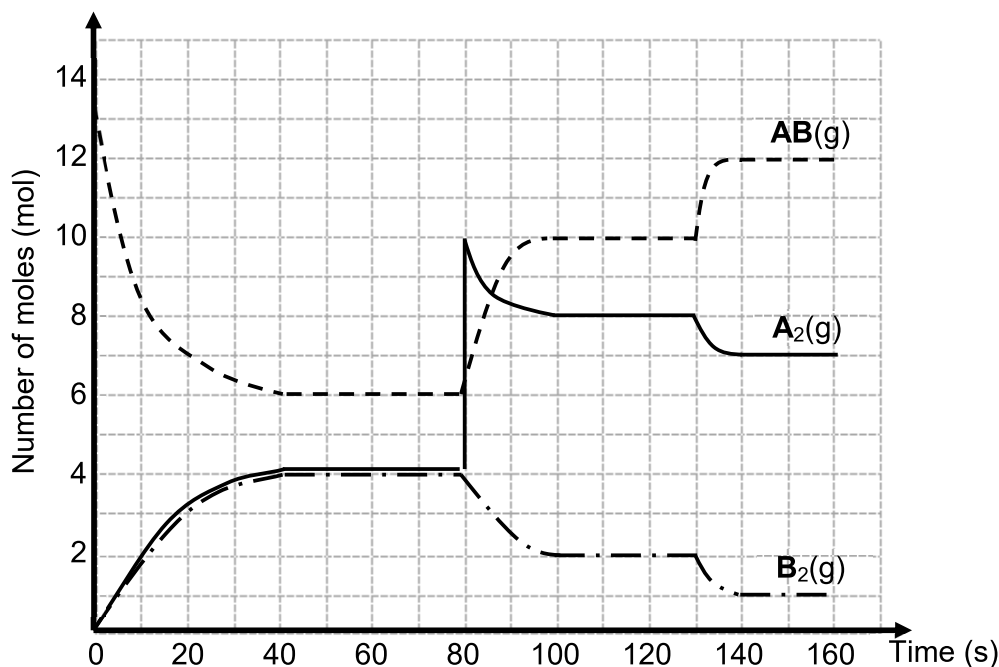

- 6.1 Write down the meaning of the term *reversible reaction*. (1)
- 6.2 State Le Chatelier's principle. (2)
- 6.3 A change was made to the equilibrium mixture at t = 80 s.
- 6.3.1 Write down the change made at t = 80 s. (1)
- 6.3.2 Use Le Chatelier's principle to explain how the system reacts to this change. (2)
- 6.4 Calculate the equilibrium constant, K_c , at t = 120 s. (4)
- 6.5 At t = 130 s the temperature of the system is decreased to 100 °C.
- 6.5.1 Draw a potential energy diagram for this reaction. (3)
- 6.5.2 Will the equilibrium constant, K_c , at 100 °C be GREATER THAN, LESS THAN or EQUAL TO the K_c at 150 °C? Explain the answer. (3)
- 6.6 The initial reaction now takes place in the presence of a catalyst at 150 °C.
- Describe the changes that will be observed on the graph between t = 0 s and t = 60 s. (3)



QUESTION 7 (Start on a new page.)

To identify metal **M** in an unknown metal carbonate, MCO_3 , the following procedure is carried out:

Step 1: 0,198 g of IMPURE MCO_3 is reacted with 25 cm^3 of $0,4 \text{ mol}\cdot\text{dm}^{-3}$ nitric acid, $\text{HNO}_3(\text{aq})$.

Step 2: The EXCESS $\text{HNO}_3(\text{aq})$ is then neutralised with 20 cm^3 of $0,15 \text{ mol}\cdot\text{dm}^{-3}$ barium hydroxide, $\text{Ba}(\text{OH})_2(\text{aq})$.

Assume that the volumes are additive.

The following reactions take place:

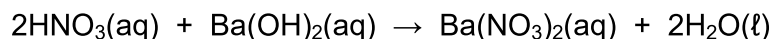

- 7.1 Define the term *strong base*. (2)
- 7.2 Calculate the:
- 7.2.1 Number of moles of $\text{Ba}(\text{OH})_2(\text{aq})$ that reacted with the excess $\text{HNO}_3(\text{aq})$ (3)
- 7.2.2 pH of the solution after Step 1 (5)
- 7.3 The percentage purity of the $\text{MCO}_3(\text{s})$ in the sample is 85%. Identify metal **M**. (8)
- [18]**

QUESTION 8 (Start on a new page.)

A cleaned pure copper strip, Cu(s) , is placed in a beaker containing a colourless silver nitrate solution, $\text{AgNO}_3(\text{aq})$, at $25\text{ }^\circ\text{C}$, as shown below.

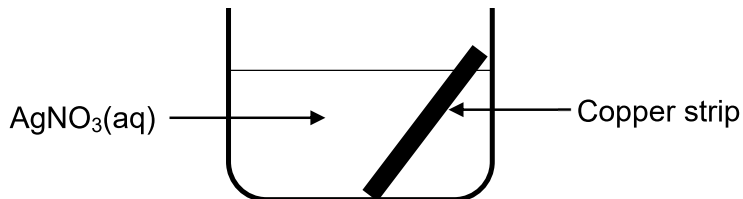

After a while, it is observed that the solution in the beaker becomes blue.

8.1 Write down:

8.1.1 ONE other OBSERVABLE change, besides the solution turning blue (1)

8.1.2 The NAME or FORMULA of the oxidising agent (1)

8.2 Explain the answer to QUESTION 8.1.1 by referring to the relative strengths of the oxidising agents or reducing agents. (3)

A galvanic cell is now set up using Cu and Ag strips as electrodes. A simplified diagram of the cell is shown below.

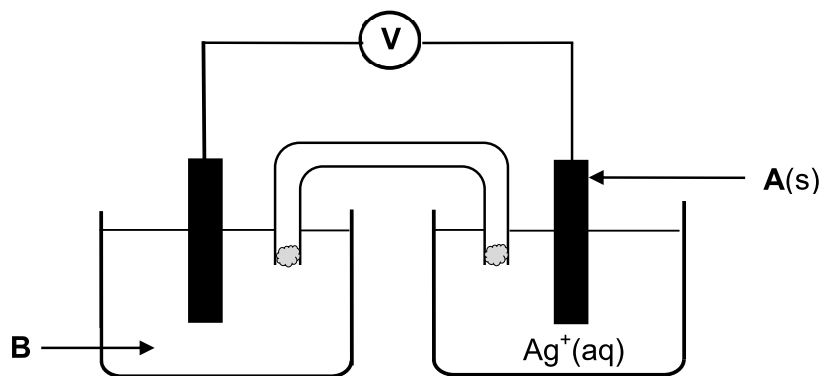

8.3 Write down the:

8.3.1 NAME or FORMULA of electrode **A** (1)

8.3.2 NAME or FORMULA of solution **B** (1)

8.3.3 Overall (net) balanced equation for the cell reaction (3)

8.4 The salt bridge contains potassium nitrate, $\text{KNO}_3(\text{aq})$.

Write down the FORMULA of the ion in the salt bridge that will move into the silver ion solution. Choose from $\text{K}^+(\text{aq})$ or $\text{NO}_3^-(\text{aq})$.

Give a reason for the answer.

(2)
[12]

QUESTION 9 (Start on a new page.)

An electrolytic cell is set up to purify a piece of copper that contains silver and zinc as impurities. A simplified diagram of the cell is shown below. Electrode **R** is impure copper.

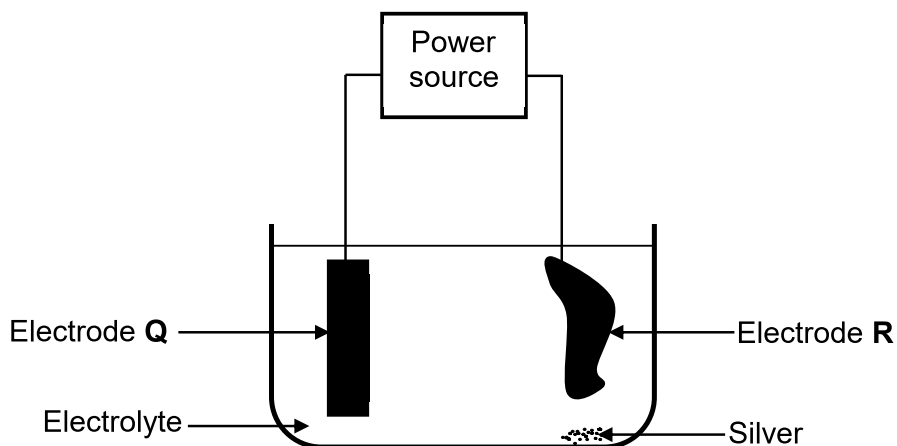

- 9.1 Define the term *electrolysis*. (2)
- 9.2 Write down the reaction taking place at electrode **Q**. (2)
- 9.3 In which direction do the electrons flow in the external circuit? Choose from **Q to R** or **R to Q**. (1)
- 9.4 Calculate the current needed to form 16 g of copper when the cell operates for five hours. (5)
- 9.5 During this electrolysis, only copper and zinc are oxidised.
Give a reason why the silver is not oxidised. (2)

[12]**TOTAL: 150**

**DATA FOR PHYSICAL SCIENCES GRADE 12
PAPER 2 (CHEMISTRY)**

**GEGEWENS VIR FISIESTE WETENSAPPE GRAAD 12
VRAESTEL 2 (CHEMIE)**

TABLE 1: PHYSICAL CONSTANTS/TABEL 1: FISIESTE KONSTANTES

NAME/NAAM	SYMBOL/SIMBOOL	VALUE/WAARDE
Standard pressure <i>Standaarddruk</i>	p^θ	$1,013 \times 10^5 \text{ Pa}$
Molar gas volume at STP <i>Molêre gasvolume by STD</i>	V_m	$22,4 \text{ dm}^3 \cdot \text{mol}^{-1}$
Standard temperature <i>Standaardtemperatuur</i>	T^θ	273 K
Charge on electron <i>Lading op elektron</i>	e	$-1,6 \times 10^{-19} \text{ C}$
Avogadro's constant <i>Avogadro-konstante</i>	N_A	$6,02 \times 10^{23} \text{ mol}^{-1}$

TABLE 2: FORMULAE/TABEL 2: FORMULES

$n = \frac{m}{M}$	$n = \frac{N}{N_A}$
$c = \frac{n}{V}$ or/of $c = \frac{m}{MV}$	$n = \frac{V}{V_m}$
$\frac{c_a V_a}{c_b V_b} = \frac{n_a}{n_b}$	$\text{pH} = -\log[\text{H}_3\text{O}^+]$
$K_w = [\text{H}_3\text{O}^+][\text{OH}^-] = 1 \times 10^{-14}$ at/by 298 K	
$E_{\text{cell}}^\theta = E_{\text{cathode}}^\theta - E_{\text{anode}}^\theta$ / $E_{\text{sel}}^\theta = E_{\text{katode}}^\theta - E_{\text{anode}}^\theta$ or/of $E_{\text{cell}}^\theta = E_{\text{reduction}}^\theta - E_{\text{oxidation}}^\theta$ / $E_{\text{sel}}^\theta = E_{\text{reduksie}}^\theta - E_{\text{oksidasie}}^\theta$ or/of $E_{\text{cell}}^\theta = E_{\text{oxidising agent}}^\theta - E_{\text{reducing agent}}^\theta$ / $E_{\text{sel}}^\theta = E_{\text{oksideermiddel}}^\theta - E_{\text{reduseermiddel}}^\theta$	
$I = \frac{Q}{\Delta t}$	$n = \frac{Q}{q_e}$ where n is the number of electrons/ waar n die aantal elektrone is

TABLE 4A: STANDARD REDUCTION POTENTIALS
TABEL 4A: STANDAARD-REDUKSIEPOTENSIALE

Increasing strength of oxidising agents/Toenemende sterkte van oksideermiddels

Half-reactions/Halfreaksies	E^{θ} (V)
$F_2(g) + 2e^- \rightleftharpoons 2F^-$	+ 2,87
$Co^{3+} + e^- \rightleftharpoons Co^{2+}$	+ 1,81
$H_2O_2 + 2H^+ + 2e^- \rightleftharpoons 2H_2O$	+1,77
$MnO_4^- + 8H^+ + 5e^- \rightleftharpoons Mn^{2+} + 4H_2O$	+ 1,51
$Cl_2(g) + 2e^- \rightleftharpoons 2Cl^-$	+ 1,36
$Cr_2O_7^{2-} + 14H^+ + 6e^- \rightleftharpoons 2Cr^{3+} + 7H_2O$	+ 1,33
$O_2(g) + 4H^+ + 4e^- \rightleftharpoons 2H_2O$	+ 1,23
$MnO_2 + 4H^+ + 2e^- \rightleftharpoons Mn^{2+} + 2H_2O$	+ 1,23
$Pt^{2+} + 2e^- \rightleftharpoons Pt$	+ 1,20
$Br_2(l) + 2e^- \rightleftharpoons 2Br^-$	+ 1,07
$NO_3^- + 4H^+ + 3e^- \rightleftharpoons NO(g) + 2H_2O$	+ 0,96
$Hg^{2+} + 2e^- \rightleftharpoons Hg(l)$	+ 0,85
$Ag^+ + e^- \rightleftharpoons Ag$	+ 0,80
$NO_3^- + 2H^+ + e^- \rightleftharpoons NO_2(g) + H_2O$	+ 0,80
$Fe^{3+} + e^- \rightleftharpoons Fe^{2+}$	+ 0,77
$O_2(g) + 2H^+ + 2e^- \rightleftharpoons H_2O_2$	+ 0,68
$I_2 + 2e^- \rightleftharpoons 2I^-$	+ 0,54
$Cu^+ + e^- \rightleftharpoons Cu$	+ 0,52
$SO_2 + 4H^+ + 4e^- \rightleftharpoons S + 2H_2O$	+ 0,45
$2H_2O + O_2 + 4e^- \rightleftharpoons 4OH^-$	+ 0,40
$Cu^{2+} + 2e^- \rightleftharpoons Cu$	+ 0,34
$SO_4^{2-} + 4H^+ + 2e^- \rightleftharpoons SO_2(g) + 2H_2O$	+ 0,17
$Cu^{2+} + e^- \rightleftharpoons Cu^+$	+ 0,16
$Sn^{4+} + 2e^- \rightleftharpoons Sn^{2+}$	+ 0,15
$S + 2H^+ + 2e^- \rightleftharpoons H_2S(g)$	+ 0,14
$2H^+ + 2e^- \rightleftharpoons H_2(g)$	0,00
$Fe^{3+} + 3e^- \rightleftharpoons Fe$	- 0,06
$Pb^{2+} + 2e^- \rightleftharpoons Pb$	- 0,13
$Sn^{2+} + 2e^- \rightleftharpoons Sn$	- 0,14
$Ni^{2+} + 2e^- \rightleftharpoons Ni$	- 0,27
$Co^{2+} + 2e^- \rightleftharpoons Co$	- 0,28
$Cd^{2+} + 2e^- \rightleftharpoons Cd$	- 0,40
$Cr^{3+} + e^- \rightleftharpoons Cr^{2+}$	- 0,41
$Fe^{2+} + 2e^- \rightleftharpoons Fe$	- 0,44
$Cr^{3+} + 3e^- \rightleftharpoons Cr$	- 0,74
$Zn^{2+} + 2e^- \rightleftharpoons Zn$	- 0,76
$2H_2O + 2e^- \rightleftharpoons H_2(g) + 2OH^-$	- 0,83
$Cr^{2+} + 2e^- \rightleftharpoons Cr$	- 0,91
$Mn^{2+} + 2e^- \rightleftharpoons Mn$	- 1,18
$Al^{3+} + 3e^- \rightleftharpoons Al$	- 1,66
$Mg^{2+} + 2e^- \rightleftharpoons Mg$	- 2,36
$Na^+ + e^- \rightleftharpoons Na$	- 2,71
$Ca^{2+} + 2e^- \rightleftharpoons Ca$	- 2,87
$Sr^{2+} + 2e^- \rightleftharpoons Sr$	- 2,89
$Ba^{2+} + 2e^- \rightleftharpoons Ba$	- 2,90
$Cs^+ + e^- \rightleftharpoons Cs$	- 2,92
$K^+ + e^- \rightleftharpoons K$	- 2,93
$Li^+ + e^- \rightleftharpoons Li$	- 3,05

Increasing strength of reducing agents/Toenemende sterkte van reduseermiddels

TABLE 4B: STANDARD REDUCTION POTENTIALS
TABEL 4B: STANDAARD-REDUKSIEPOTENSIALE

Increasing strength of oxidising agents/Toenemende sterkte van oksideermiddels

Half-reactions/Halfreaksies	E^{θ} (V)
$\text{Li}^{+} + \text{e}^{-} \rightleftharpoons \text{Li}$	- 3,05
$\text{K}^{+} + \text{e}^{-} \rightleftharpoons \text{K}$	- 2,93
$\text{Cs}^{+} + \text{e}^{-} \rightleftharpoons \text{Cs}$	- 2,92
$\text{Ba}^{2+} + 2\text{e}^{-} \rightleftharpoons \text{Ba}$	- 2,90
$\text{Sr}^{2+} + 2\text{e}^{-} \rightleftharpoons \text{Sr}$	- 2,89
$\text{Ca}^{2+} + 2\text{e}^{-} \rightleftharpoons \text{Ca}$	- 2,87
$\text{Na}^{+} + \text{e}^{-} \rightleftharpoons \text{Na}$	- 2,71
$\text{Mg}^{2+} + 2\text{e}^{-} \rightleftharpoons \text{Mg}$	- 2,36
$\text{Al}^{3+} + 3\text{e}^{-} \rightleftharpoons \text{Al}$	- 1,66
$\text{Mn}^{2+} + 2\text{e}^{-} \rightleftharpoons \text{Mn}$	- 1,18
$\text{Cr}^{2+} + 2\text{e}^{-} \rightleftharpoons \text{Cr}$	- 0,91
$2\text{H}_2\text{O} + 2\text{e}^{-} \rightleftharpoons \text{H}_2(\text{g}) + 2\text{OH}^{-}$	- 0,83
$\text{Zn}^{2+} + 2\text{e}^{-} \rightleftharpoons \text{Zn}$	- 0,76
$\text{Cr}^{3+} + 3\text{e}^{-} \rightleftharpoons \text{Cr}$	- 0,74
$\text{Fe}^{2+} + 2\text{e}^{-} \rightleftharpoons \text{Fe}$	- 0,44
$\text{Cr}^{3+} + \text{e}^{-} \rightleftharpoons \text{Cr}^{2+}$	- 0,41
$\text{Cd}^{2+} + 2\text{e}^{-} \rightleftharpoons \text{Cd}$	- 0,40
$\text{Co}^{2+} + 2\text{e}^{-} \rightleftharpoons \text{Co}$	- 0,28
$\text{Ni}^{2+} + 2\text{e}^{-} \rightleftharpoons \text{Ni}$	- 0,27
$\text{Sn}^{2+} + 2\text{e}^{-} \rightleftharpoons \text{Sn}$	- 0,14
$\text{Pb}^{2+} + 2\text{e}^{-} \rightleftharpoons \text{Pb}$	- 0,13
$\text{Fe}^{3+} + 3\text{e}^{-} \rightleftharpoons \text{Fe}$	- 0,06
$2\text{H}^{+} + 2\text{e}^{-} \rightleftharpoons \text{H}_2(\text{g})$	0,00
$\text{S} + 2\text{H}^{+} + 2\text{e}^{-} \rightleftharpoons \text{H}_2\text{S}(\text{g})$	+ 0,14
$\text{Sn}^{4+} + 2\text{e}^{-} \rightleftharpoons \text{Sn}^{2+}$	+ 0,15
$\text{Cu}^{2+} + \text{e}^{-} \rightleftharpoons \text{Cu}^{+}$	+ 0,16
$\text{SO}_4^{2-} + 4\text{H}^{+} + 2\text{e}^{-} \rightleftharpoons \text{SO}_2(\text{g}) + 2\text{H}_2\text{O}$	+ 0,17
$\text{Cu}^{2+} + 2\text{e}^{-} \rightleftharpoons \text{Cu}$	+ 0,34
$2\text{H}_2\text{O} + \text{O}_2 + 4\text{e}^{-} \rightleftharpoons 4\text{OH}^{-}$	+ 0,40
$\text{SO}_2 + 4\text{H}^{+} + 4\text{e}^{-} \rightleftharpoons \text{S} + 2\text{H}_2\text{O}$	+ 0,45
$\text{Cu}^{+} + \text{e}^{-} \rightleftharpoons \text{Cu}$	+ 0,52
$\text{I}_2 + 2\text{e}^{-} \rightleftharpoons 2\text{I}^{-}$	+ 0,54
$\text{O}_2(\text{g}) + 2\text{H}^{+} + 2\text{e}^{-} \rightleftharpoons \text{H}_2\text{O}_2$	+ 0,68
$\text{Fe}^{3+} + \text{e}^{-} \rightleftharpoons \text{Fe}^{2+}$	+ 0,77
$\text{NO}_3^{-} + 2\text{H}^{+} + \text{e}^{-} \rightleftharpoons \text{NO}_2(\text{g}) + \text{H}_2\text{O}$	+ 0,80
$\text{Ag}^{+} + \text{e}^{-} \rightleftharpoons \text{Ag}$	+ 0,80
$\text{Hg}^{2+} + 2\text{e}^{-} \rightleftharpoons \text{Hg}(\ell)$	+ 0,85
$\text{NO}_3^{-} + 4\text{H}^{+} + 3\text{e}^{-} \rightleftharpoons \text{NO}(\text{g}) + 2\text{H}_2\text{O}$	+ 0,96
$\text{Br}_2(\ell) + 2\text{e}^{-} \rightleftharpoons 2\text{Br}^{-}$	+ 1,07
$\text{Pt}^{2+} + 2\text{e}^{-} \rightleftharpoons \text{Pt}$	+ 1,20
$\text{MnO}_2 + 4\text{H}^{+} + 2\text{e}^{-} \rightleftharpoons \text{Mn}^{2+} + 2\text{H}_2\text{O}$	+ 1,23
$\text{O}_2(\text{g}) + 4\text{H}^{+} + 4\text{e}^{-} \rightleftharpoons 2\text{H}_2\text{O}$	+ 1,23
$\text{Cr}_2\text{O}_7^{2-} + 14\text{H}^{+} + 6\text{e}^{-} \rightleftharpoons 2\text{Cr}^{3+} + 7\text{H}_2\text{O}$	+ 1,33
$\text{Cl}_2(\text{g}) + 2\text{e}^{-} \rightleftharpoons 2\text{Cl}^{-}$	+ 1,36
$\text{MnO}_4^{-} + 8\text{H}^{+} + 5\text{e}^{-} \rightleftharpoons \text{Mn}^{2+} + 4\text{H}_2\text{O}$	+ 1,51
$\text{H}_2\text{O}_2 + 2\text{H}^{+} + 2\text{e}^{-} \rightleftharpoons 2\text{H}_2\text{O}$	+ 1,77
$\text{Co}^{3+} + \text{e}^{-} \rightleftharpoons \text{Co}^{2+}$	+ 1,81
$\text{F}_2(\text{g}) + 2\text{e}^{-} \rightleftharpoons 2\text{F}^{-}$	+ 2,87

Increasing strength of reducing agents/Toenemende sterkte van reduseermiddels

