

SA's Leading Past Year

Exam Paper Portal



You have Downloaded, yet Another Great Resource to assist you with your Studies 😊

Thank You for Supporting SA Exam Papers

Your Leading Past Year Exam Paper Resource Portal

Visit us @ www.saexampapers.co.za





PREPARATORY EXAMINATION

2023

10841

PHYSICAL SCIENCES: PHYSICS

(PAPER 1)

TIME: 3 hours

MARKS: 150

PHYSICAL SCIENCES: Paper 1



10841E

X05



14 pages + 3 information sheets and 1 answer sheet



P.T.O.

INSTRUCTIONS AND INFORMATION

1. Write your name in the appropriate space on the ANSWER BOOK.
2. This question paper consists of TEN questions. Answer ALL the questions in the ANSWER BOOK.
3. Start EACH question (e.g. QUESTION 2 and QUESTION 3) on a NEW page.
4. Number the answers correctly according to the numbering system used in this question paper.
5. Leave ONE line open between subquestions, e.g. between QUESTION 2.1 and QUESTION 2.2.
6. You may use a non-programmable calculator.
7. You may use appropriate mathematical instruments.
8. You are advised to use the attached information sheets.
9. Show ALL formulae and substitutions in ALL calculations.
10. Round-off your FINAL numerical answers to a minimum of TWO decimal places, where applicable.
11. Give short, brief motivations, discussions, et cetera, where required.
12. Write neatly and legibly.

QUESTION 1: MULTIPLE-CHOICE QUESTIONS

Four options are provided as possible answers to the following questions. Each question has only ONE correct answer. Choose the answer and write only the letter (A – D) next to the question numbers (1.1 to 1.10) in the ANSWER BOOK, e.g. 1.11 D.

- 1.1 The diagram below shows a trolley held stationary on a slope by a spring balance that has a reading of X newtons. The weight of the trolley is w and there is friction f , between the trolley's wheels and the slope.

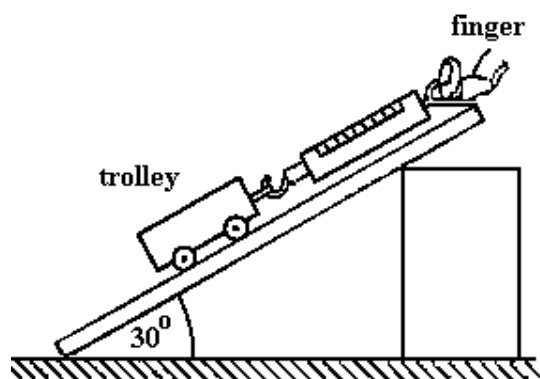

The reading on the spring balance is ...

- A w .
 B $w + f$.
 C $w - f$.
 D $w \sin 30$. (2)
- 1.2 A box M is being pushed horizontally at a constant velocity on a rough surface by a force F .

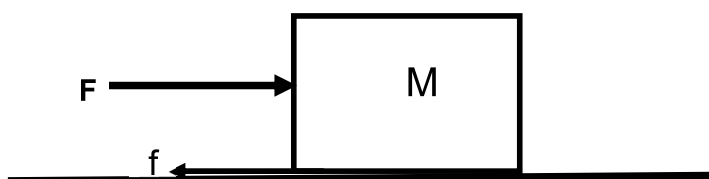

If the force F acting on the box decreases, then the ...

- A frictional force acting on the box decreases.
 B velocity of the box decreases.
 C acceleration of the box increases.
 D normal force increases. (2)

- 1.7 The diagram below shows two point charges $Q_1 = +5q$ and $Q_2 = -4q$ at a distance x (m) from point P.

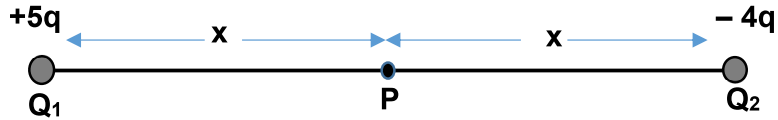

The net electric field at point P in terms of E is given by:

- A 4 E left
 B 5 E right
 C 5 E left
 D 9 E right
- (2)
- 1.8 The circuit below is set up. The battery has an EMF of 9 V and an internal resistance of $0,2 \Omega$. The reading on A_1 is 1,8 A.

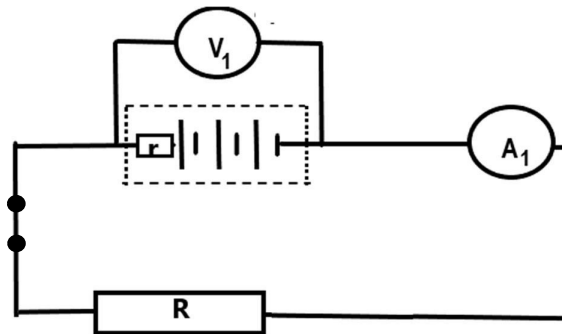

Which statement is CORRECT when a charge of 1 C flows in the circuit?

- A 9 V is the potential difference across the resistor.
 B 9 J of energy is dissipated in the resistor.
 C 8,64 A is flowing in the circuit.
 D 8,64 J of energy is dissipated in the resistor.
- (2)
- 1.9 An EMF can be induced across a stationary coil by ...
- A a stationary magnetic field.
 B using more turns on the coil.
 C a changing magnetic field.
 D increasing the area of the coil.
- (2)

1.10 The diagram below shows the energy levels of an atom in eV (electron volts).

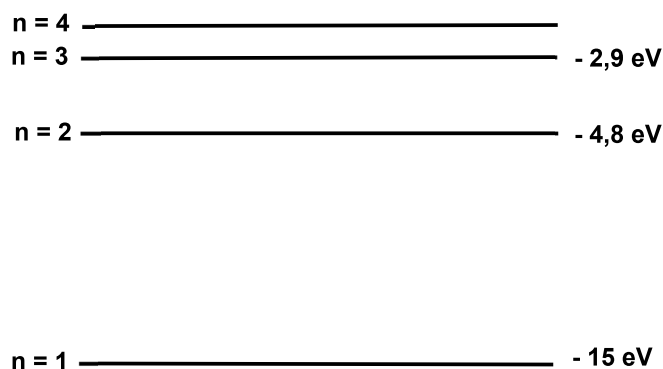

The energy needed to excite an electron from the ground state to the first excited state is:

- A $- 2,9 \text{ eV}$
- B $- 4,8 \text{ eV}$
- C $+ 10,2 \text{ eV}$
- D $- 10,2 \text{ eV}$

(2)
[20]

QUESTION 2 (Start on a new page.)

Two blocks are attached to each other by a light inextensible string moving over a frictionless pulley as shown in the diagram below. The slope **AB** has a smooth surface and makes an angle of 50° with the horizontal. The slope **BC** has a rough surface and makes an angle of 30° with the horizontal.

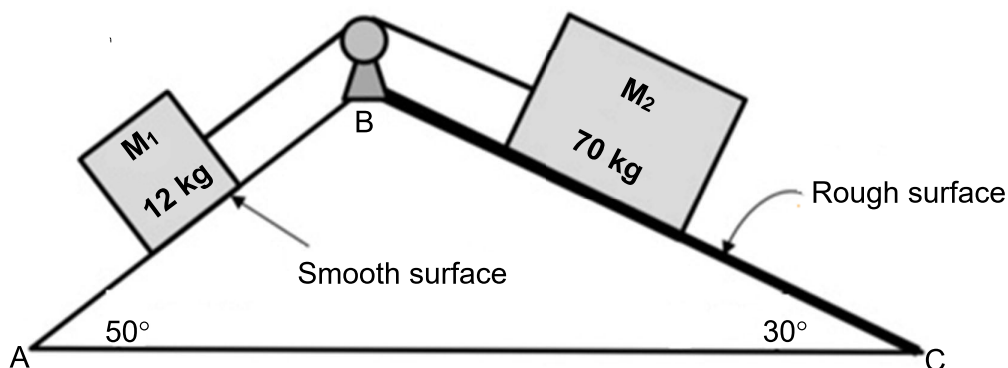

2.1 State *Newton's second law of motion* in words. (2)

2.2 The coefficient of kinetic friction between slope **BC** and the block M_2 is 0,2.

2.2.1 Draw a labelled free-body diagram for block M_2 . (4)

2.2.2 Calculate the magnitude of the acceleration of the system. Show ALL steps in your calculation. (8)

- 2.3 If the angle of slope **BC** is decreased to 20° , will the frictional force between the block and the slope INCREASE, DECREASE or REMAIN THE SAME? Explain the answer. (NOTE: No calculations are needed.)

(3)
[17]**QUESTION 3 (Start on a new page.)**

A 25 g ball is thrown vertically upwards. The ball leaves the thrower's hand 1,3 m above the ground with an initial velocity of $7,27 \text{ m}\cdot\text{s}^{-1}$. On its way down, the ball bounces off a balcony at a velocity of $3 \text{ m}\cdot\text{s}^{-1}$ before being caught at its maximum height after the bounce. Ignore all effects of friction as well as any horizontal motion of the ball.

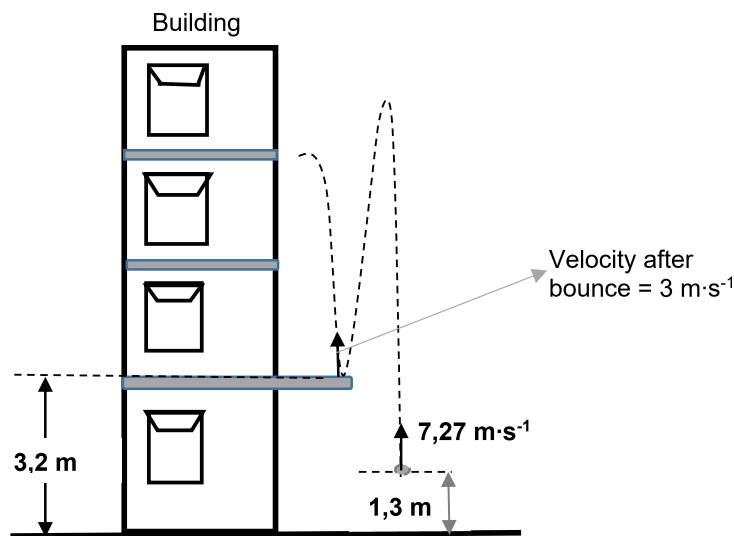

- 3.1 Define the term *projectile*. (2)
- 3.2 Calculate the:
- 3.2.1 Maximum height above the ground that the ball will reach after it was thrown in the air (4)
- 3.2.2 Time that the ball takes until it bounces on the balcony for the first time. (3)
- 3.3 Draw a sketch graph of the displacement of the ball for the entire motion. (Use the ground as the reference point.)

Clearly indicate the following on your graph:

- The height from which the ball is released
- The maximum height that the ball reaches
- The height of the balcony
- The time that it takes to bounce on the balcony

(5)
[14]

QUESTION 4 (Start on a new page.)

When a ball hits and bounces off a surface, it exerts a force on that surface. Grade 12 learners investigated how this force varies over time as the ball hits a force sensor and bounces off. A 50 g soft ball was dropped from a height of 1,5 m vertically above a force sensor connected to a laptop as shown on the diagram.

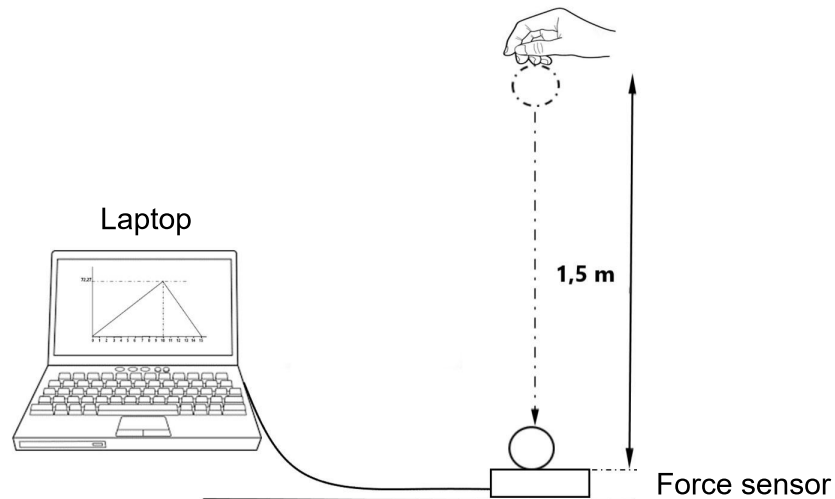

The following graph is obtained from the laptop:

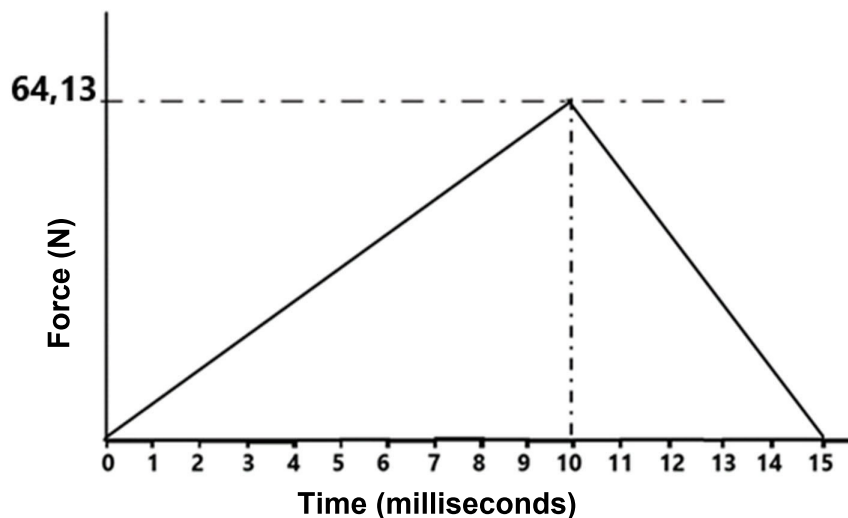

- 4.1 Define the term *impulse*. (2)
- 4.2 Use the information on the graph to determine the magnitude of the impulse as the ball hits and bounces off the force sensor. (2)
- 4.3 State the magnitude and the direction of the change in the momentum of the ball. (2)

- 4.4 If the velocity of the ball just before it hits the force sensor is $5,42 \text{ m}\cdot\text{s}^{-1}$ downwards, calculate the velocity with which the ball will bounce off the sensor. (4)
- 4.5 The ball is now replaced with a hard ball of the same size and mass. Will the force on the force sensor INCREASE, DECREASE OR REMAIN THE SAME? Explain the answer. (3)
- [13]

QUESTION 5 (Start on a new page.)

A 5 kg box moves up an inclined plane **AB** at a constant velocity of $1,2 \text{ m}\cdot\text{s}^{-1}$ when a force **F**, is applied.

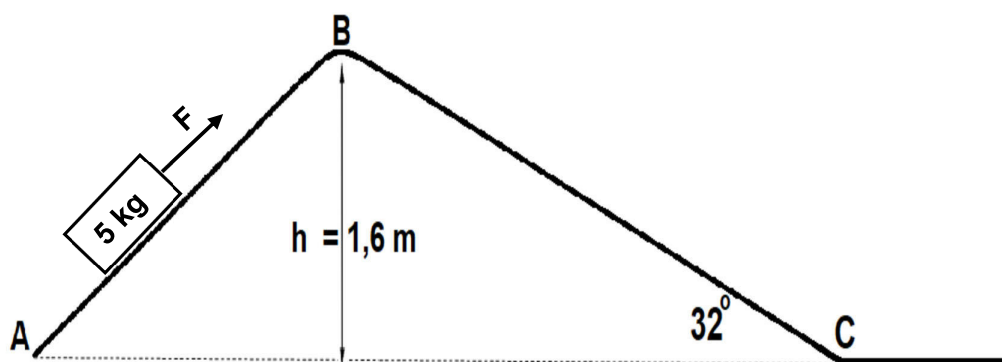

- 5.1 Calculate the magnitude of the force **F** if the power that is used to move the box up the incline **AB** is equal to $57,6 \text{ W}$. (3)
- 5.2 State the *work-energy theorem* in words. (2)
- 5.3 The box now slides down slope **BC**.

If the coefficient of kinetic friction of slope **BC** in the diagram above is $0,25$, calculate the velocity of the block at point **C**, by using ENERGY PRINCIPLES only. (6)

[11]

QUESTION 6 (Start on a new page.)

In the diagrams **A**, **B** and **C** below, the wave patterns are shown for the sound of a siren from an ambulance and a stationary observer. The observer remains stationary in each case.

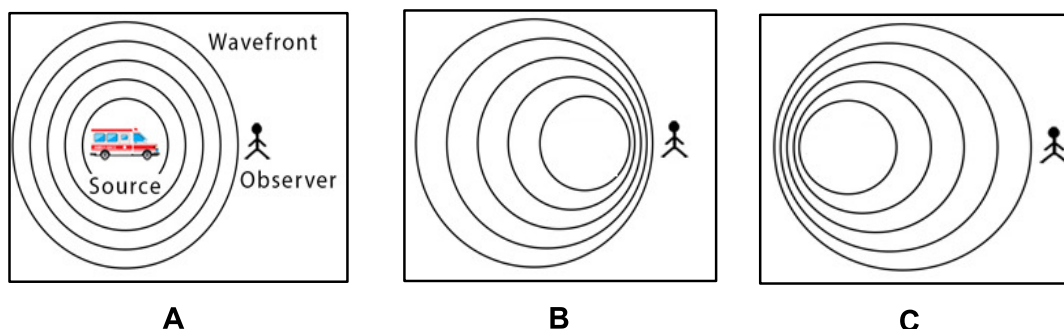

- 6.1 Define the term *Doppler effect*. (2)
- 6.2 For QUESTIONS 6.2.1 and 6.2.2, state either **A**; **B** or **C**, for which:
- 6.2.1 The sound source is stationary. (1)
- 6.2.2 The sound source is moving away from the observer. (1)
- 6.2.3 Give a reason for the answer in QUESTION 6.2.2. (1)
- 6.3 If the ambulance is moving away from the observer at a speed of $25 \text{ m}\cdot\text{s}^{-1}$, and the frequency of its siren as heard by the driver is 900 Hz , calculate the frequency observed by the observer. Take the speed of sound in air as $340 \text{ m}\cdot\text{s}^{-1}$. (5)
- 6.4 The hydrogen spectral line from the sun has a wavelength of 656 nm . If this spectral line from a nearby star has a wavelength of 657 nm , what can we conclude about the motion of this star in relation to the sun? Explain this observation in terms of the Doppler effect. (3)
- [13]**

QUESTION 7 (Start on a new page.)

An investigation was carried out to show how the electric field (**E**) varies at a fixed distance away from a positively charged sphere. To achieve this, a positive charge **Q** was varied, and the respective electric field **E** was measured. The following table of results was obtained.

CHARGE (Q) in nC	ELECTRIC FIELD (E) in $\text{kN}\cdot\text{C}^{-1}$
1	4
4	16
8	32
11	44
14	55

The questions below refer to the table and the investigation that was conducted.

- 7.1 Define the term *electric field at a point*. (2)
- 7.2 Draw the electric field pattern for a positively charged particle. (2)
- 7.3 Plot the graph for electric field (**E**) versus charge (**Q**). Use the GRAPH PAPER provided at the end of the question paper. (4)
- 7.4 Use the graph **ONLY** to answer the following questions:
- 7.4.1 Identify the controlled variable in this investigation. (1)
- 7.4.2 Identify the dependent variable in this investigation. (1)
- 7.4.3 Determine the fixed distance between the charge and the point where the electric field is measured. (5)
- [15]**

QUESTION 8 (Start on a new page.)

The battery in the circuit diagram below has an EMF of **6 V** and an internal resistance of $0,4 \Omega$.

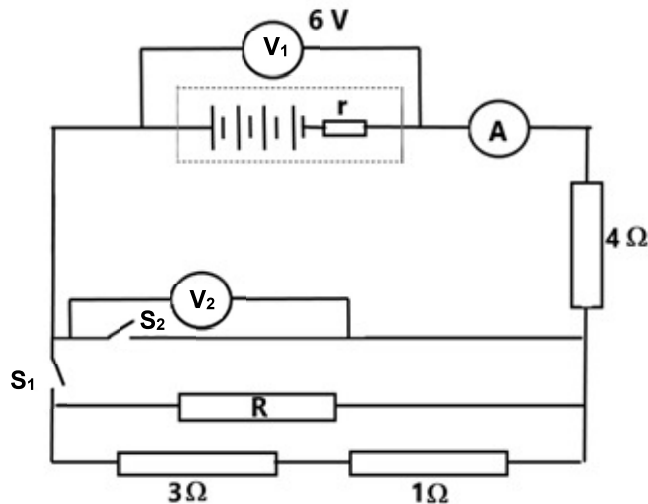

- 8.1 With both S_1 and S_2 open, give the reading on V_2 . (1)
- 8.2 With only S_1 closed, the ammeter records a reading of $0,75 \text{ A}$. Explain the meaning of $0,75 \text{ A}$. (2)
- 8.3 With only S_1 closed, calculate the:
- 8.3.1 External resistance of the circuit (3)
- 8.3.2 Resistance of resistor R (3)

- 8.4 S_1 is now open and S_2 is closed. How will the power dissipated by the $4\ \Omega$ resistor change? Write only INCREASE, DECREASE OR REMAIN THE SAME. Explain the answer. (4)

Grade 12 learners conducted an investigation to determine the internal resistance of a battery. The circuit used is shown below. By varying the rheostat settings, the corresponding values of the circuit current and the potential difference, V_2 , were recorded.

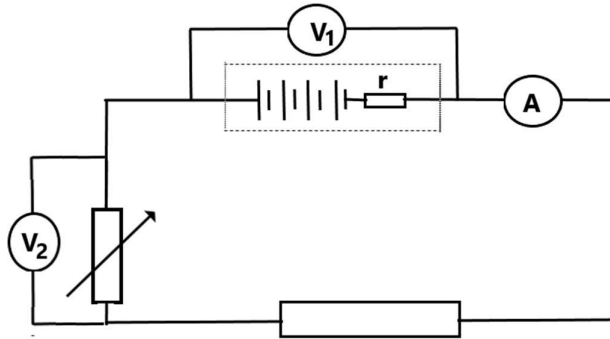

The results obtained were used to plot the graph below.

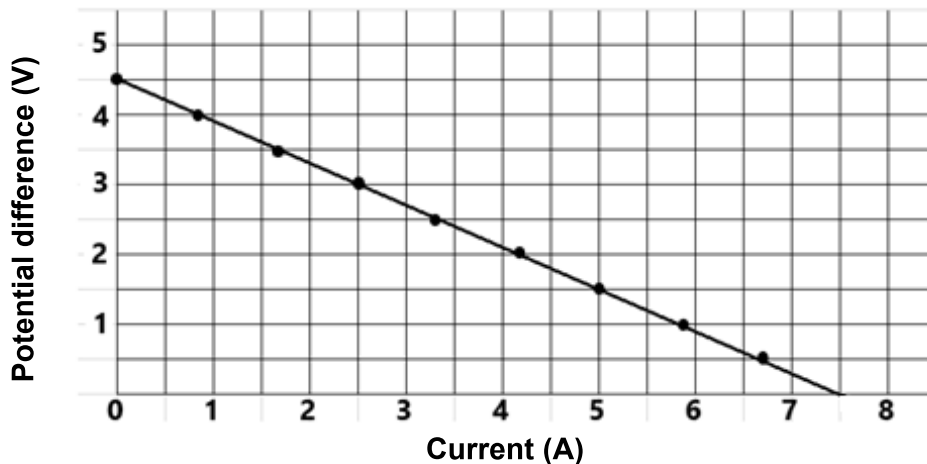

- 8.5 From this graph:

8.5.1 Deduce the EMF of the battery. (1)

8.5.2 Calculate the internal resistance of the battery. (3)

[17]

QUESTION 9 (Start on a new page.)

Study the diagram below and answer the questions that follow.

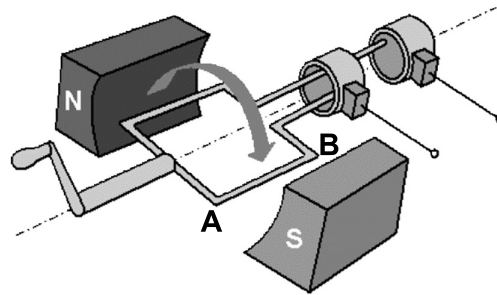

- 9.1 What type of generator is shown in the diagram above? Motivate the answer by referring to the names of specific components in the diagram. (3)
- 9.2 Indicate the direction in which the current will flow in section **AB**. Use **A to B** or **B to A**. (1)
- 9.3 The following graph is obtained from an AC generator.

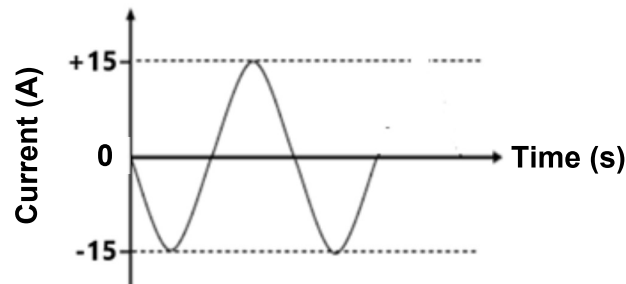

- 9.3.1 How many rotations of the coil are shown in the diagram? (2)
- 9.3.2 Define *rms current*. (2)
- 9.3.3 Calculate the average power that can be delivered by this generator to an apparatus with a resistance of $30\ \Omega$. (5)
- 9.4 An electric hair dryer is rated at $2\ 200\ \text{W}$ at $240\ \text{V}$. Assume that the hair dryer is a pure resistor. Calculate the maximum current that flows through the hair dryer when it is used. (4)

[17]

QUESTION 10 (Start on a new page.)

The diagram below shows a phototube that was used to demonstrate the photoelectric effect. The demonstration was carried out by shining light from a red; a green; a blue and an ultraviolet light source onto the surface of the phototube.

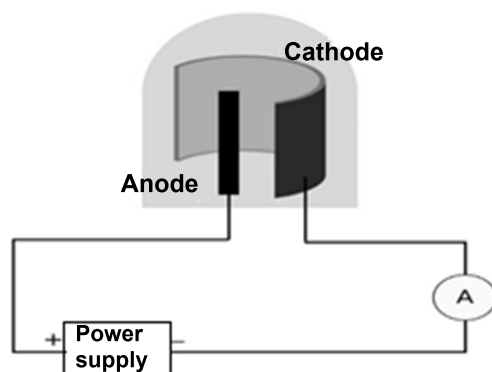

The results were recorded in the table below.

DEMONSTRATION NUMBER	COLOUR OF LIGHT USED	READING ON AMMETER
1	Red	No
2	Green	Yes
3	Blue	Yes
4	Ultraviolet	Yes

- 10.1 Explain what is meant by the *photoelectric effect*. (2)
- 10.2 Explain why there is no reading on the ammeter when a red light is used. (2)
- 10.3 For the following statements, use INCREASES, DECREASES or REMAINS THE SAME to complete the statement:
- 10.3.1 The kinetic energy of the photoelectrons ... when ultraviolet light is shone onto the surface of the phototube instead of green light. (1)
- 10.3.2 The reading on the ammeter ... when green light of higher intensity is shone onto the surface of the phototube. Explain this observation. (3)
- 10.4 The cathode is made of copper with a work function of $3,52 \times 10^{-19}$ J. If ultraviolet light with a wavelength of 390 nm was used during demonstration 4, calculate the speed of the photoelectrons that were ejected. (5)

[13]**TOTAL: 150**

**DATA FOR PHYSICAL SCIENCES GRADE 12
PAPER 1 (PHYSICS)**

**GEGEWENS VIR FISIESTE WETENSAPPE GRAAD 12
VRAESTEL 1 (FISIKA)**

TABLE 1: PHYSICAL CONSTANTS/TABEL 1: FISIESTE KONSTANTES

NAME/NAAM	SYMBOL/SIMBOOL	VALUE/WAARDE
Acceleration due to gravity <i>Swaartekragversnelling</i>	g	9,8 m·s ⁻²
Universal gravitational constant <i>Universele gravitasiekonstant</i>	G	6,67 x 10 ⁻¹¹ N·m ² ·kg ⁻²
Radius of the Earth <i>Radius van die Aarde</i>	R _E	6,38 x 10 ⁶ m
Mass of the Earth <i>Massa van die Aarde</i>	M _E	5,98 x 10 ²⁴ kg
Speed of light in a vacuum <i>Spoed van lig in 'n vakuum</i>	c	3,0 x 10 ⁸ m·s ⁻¹
Planck's constant <i>Planck se konstante</i>	h	6,63 x 10 ⁻³⁴ J·s
Coulomb's constant <i>Coulomb se konstante</i>	k	9,0 x 10 ⁹ N·m ² ·C ⁻²
Charge on electron <i>Lading op electron</i>	e	-1,6 x 10 ⁻¹⁹ C
Electron mass <i>Elektronmassa</i>	m _e	9,11 x 10 ⁻³¹ kg

TABLE 2: FORMULAE/TABEL 2: FORMULES**MOTION/BEWEGING**

$v_f = v_i + a \Delta t$	$\Delta x = v_i \Delta t + \frac{1}{2} a \Delta t^2$ or/of $\Delta y = v_i \Delta t + \frac{1}{2} a \Delta t^2$
$v_f^2 = v_i^2 + 2a\Delta x$ or/of $v_f^2 = v_i^2 + 2a\Delta y$	$\Delta x = \left(\frac{v_i + v_f}{2}\right) \Delta t$ or/of $\Delta y = \left(\frac{v_i + v_f}{2}\right) \Delta t$

FORCE/KRAG

$F_{\text{net}} = ma$	$p = mv$
$f_s^{\text{max}} = \mu_s N$	$f_k = \mu_k N$
$F_{\text{net}} \Delta t = \Delta p$ $\Delta p = mv_f - mv_i$	$w = mg$
$F = G \frac{m_1 m_2}{d^2}$ or/of $F = G \frac{m_1 m_2}{r^2}$	$g = G \frac{M}{d^2}$ or/of $g = G \frac{M}{r^2}$

WORK, ENERGY AND POWER/ARBEID, ENERGIE EN DRYWING

$W = F \Delta x \cos \theta$	$U = mgh$ or/of $E_p = mgh$
$K = \frac{1}{2} mv^2$ or/of $E_k = \frac{1}{2} mv^2$	$W_{\text{net}} = \Delta K$ or/of $W_{\text{net}} = \Delta E_k$ $\Delta K = K_f - K_i$ or/of $\Delta E_k = E_{kf} - E_{ki}$
$W_{\text{nc}} = \Delta K + \Delta U$ or/of $W_{\text{nc}} = \Delta E_k + \Delta E_p$	$P = \frac{W}{\Delta t}$
$P_{\text{ave}} = Fv_{\text{ave}}$ / $P_{\text{gem}} = Fv_{\text{gem}}$	

WAVES, SOUND AND LIGHT/GOLWE, KLANK EN LIG

$v = f \lambda$	$T = \frac{1}{f}$
$f_L = \frac{v \pm v_L}{v \pm v_s} f_s$ $f_L = \frac{v \pm v_L}{v \pm v_b} f_b$	$E = hf$ or/of $E = h \frac{c}{\lambda}$
$E = W_o + E_{k(\text{max})}$ or/of $E = W_o + K_{\text{max}}$ where/waar $E = hf$ and/en $W_o = hf_0$ and/en $E_{k(\text{max})} = \frac{1}{2} mv_{\text{max}}^2$ or/of $K_{\text{max}} = \frac{1}{2} mv_{\text{max}}^2$	

ELECTROSTATICS/ELEKTROSTATIKA

$F = \frac{kQ_1Q_2}{r^2}$	$E = \frac{kQ}{r^2}$
$V = \frac{W}{q}$	$E = \frac{F}{q}$
$n = \frac{Q}{e}$ or/of $n = \frac{Q}{q_e}$	

ELECTRIC CIRCUITS/ELEKTRIESE STROOMBANE

$R = \frac{V}{I}$	emf (ϵ) = $I(R + r)$ emk (ϵ) = $I(R + r)$
$R_s = R_1 + R_2 + \dots$ $\frac{1}{R_p} = \frac{1}{R_1} + \frac{1}{R_2} + \dots$	$q = I\Delta t$
$W = Vq$ $W = VI\Delta t$ $W = I^2R\Delta t$ $W = \frac{V^2\Delta t}{R}$	$P = \frac{W}{\Delta t}$ $P = VI$ $P = I^2R$ $P = \frac{V^2}{R}$

ALTERNATING CURRENT/WISSELSTROOM

$I_{\text{rms}} = \frac{I_{\text{max}}}{\sqrt{2}}$ / $I_{\text{wgk}} = \frac{I_{\text{maks}}}{\sqrt{2}}$	$P_{\text{ave}} = V_{\text{rms}}I_{\text{rms}}$ / $P_{\text{gemiddeld}} = V_{\text{wgk}}I_{\text{wgk}}$
$V_{\text{rms}} = \frac{V_{\text{max}}}{\sqrt{2}}$ / $V_{\text{wgk}} = \frac{V_{\text{maks}}}{\sqrt{2}}$	$P_{\text{ave}} = I_{\text{rms}}^2 R$ / $P_{\text{gemiddeld}} = I_{\text{wgk}}^2 R$
	$P_{\text{ave}} = \frac{V_{\text{rms}}^2}{R}$ / $P_{\text{gemiddeld}} = \frac{V_{\text{wgk}}^2}{R}$

ANSWER SHEET

QUESTION 7.3: PLACE THIS GRAPH SHEET IN YOUR ANSWER BOOK.

NAME OF LEARNER: _____

