

# SA's Leading Past Year

## Exam Paper Portal



You have Downloaded, yet Another Great Resource to assist you with your Studies 😊

Thank You for Supporting SA Exam Papers

Your Leading Past Year Exam Paper Resource Portal

Visit us @ [www.saexampapers.co.za](http://www.saexampapers.co.za)





# basic education

Department:  
Basic Education  
**REPUBLIC OF SOUTH AFRICA**

## **SENIOR CERTIFICATE EXAMINATIONS/ NATIONAL SENIOR CERTIFICATE EXAMINATIONS**

**TECHNICAL SCIENCES P1**

**2023**

**MARKS: 150**

**TIME: 3 hours**

**This question paper consists of 17 pages and 3 data sheets.**

**INSTRUCTIONS AND INFORMATION**

1. Write your centre number and examination number in the appropriate spaces on the ANSWER BOOK.
2. This question paper consists of TEN questions. Answer ALL the questions in the ANSWER BOOK.
3. Start EACH question on a NEW page in the ANSWER BOOK.
4. Number the answers correctly according to the numbering system used in this question paper.
5. Leave ONE line between two subquestions, e.g. between QUESTION 2.1 and QUESTION 2.2.
6. You may use a non-programmable calculator.
7. You may use appropriate mathematical instruments.
8. You are advised to use the attached DATA SHEETS.
9. Show ALL formulae and substitutions in ALL calculations.
10. Round off your FINAL numerical answers to a minimum of TWO decimal places.
11. Give brief motivations, discussions, etc. where required.
12. Write neatly and legibly.

**QUESTION 1: MULTIPLE-CHOICE QUESTIONS**

Various options are provided as possible answers to the following questions. Choose the answer and write only the letter (A–D) next to the question numbers (1.1 to 1.10) in the ANSWER BOOK, e.g. 1.11 D.

1.1 The property of a body to resist any change in its state of motion or rest is ...

A mass.

B force.

C inertia.

D acceleration.

(2)

1.2 The diagram below shows forces  $F_1$  and  $F_2$  that are applied on an object placed on a frictionless surface. The object accelerates to the left.

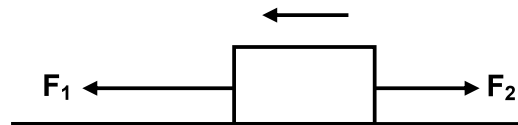

Which ONE of the following statements is CORRECT?

A  $F_1 = F_2$

B  $F_1 > F_2$

C  $F_1 < F_2$

D  $F_1 + F_2 = 0$

(2)

1.3 In physics, an isolated system is defined as a system in which ...

A the net external force acting on it is zero.

B the net external forces acting on it is greater than zero.

C only energy remains constant.

D only matter remains constant.

(2)

- 1.4 The graph below represents the work done on an object versus time taken.

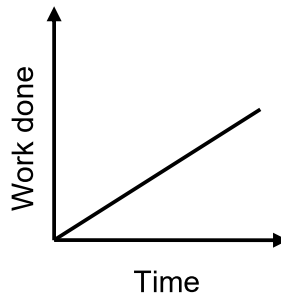

Which ONE of the following physical quantities is represented by the gradient of the graph?

- A Potential energy
- B Momentum
- C Power
- D Kinetic energy (2)
- 1.5 Which ONE of the following statements about Hooke's law is CORRECT?
- Stress is ...
- A directly proportional to strain when the elastic limit is not exceeded.
- B inversely proportional to strain when the elastic limit is exceeded.
- C directly proportional to strain when the elastic limit is exceeded.
- D inversely proportional to strain when the elastic limit is not exceeded. (2)
- 1.6 Pressure is measured in ...
- A joules.
- B watts.
- C pascal.
- D metres. (2)

- 1.7 Dispersion of light is the ...
- A bending of a light ray as it passes between media of different optical densities.
  - B change in direction of a light ray as it hits a barrier.
  - C spreading out of light as it passes around the edges of a small hole.
  - D breaking of white light into its component colours. (2)
- 1.8 Which ONE of the following units are used to measure frequency?
- A Second
  - B Decibel
  - C Hertz
  - D Joule (2)
- 1.9 The capacitance in a capacitor will increase when ...
- A a dielectric with a higher dielectric constant is used
  - B a dielectric with a lower dielectric constant is used.
  - C the distance between the plates increases.
  - D the distance between the plates decreases. (2)
- 1.10 A device that converts electric energy into mechanical energy is a ...
- A generator.
  - B capacitor.
  - C transformer.
  - D motor. (2)

**[20]**

**QUESTION 2 (Start on a new page.)**

- 2.1 Passengers sitting in a bus observe that they move forward when the bus slows down to a stop and that they move backward when it accelerates from rest.
- 2.1.1 Use physics law or principles to explain this observation as experienced by the passengers in the bus. (2)
- 2.1.2 Name and state the physics law or principle that you applied in your answer to QUESTION 2.1.1. (3)
- 2.2 A caravan of mass 900 kg is pulled by a car of mass 1 300 kg along a straight level smooth road by means of a light inextensible rope.

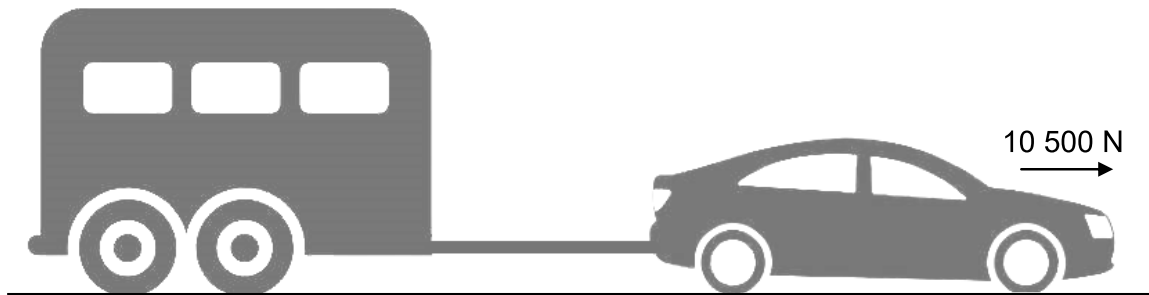

The effects of friction are ignored.

- 2.2.1 Draw a labelled free-body diagram of all the forces acting on the car. (4)
- 2.2.2 Calculate the acceleration of the system. (4)
- 2.2.3 Calculate the magnitude of the tension in the rope between the caravan and the car. (2)
- 2.3 Workers are loading equipment into a freight elevator at the top floor of a building. However, they overload the elevator and the worn-out cable snaps. The mass of the loaded elevator at the time of the accident is 1 600 kg. As the elevator falls, the guide rails exert a constant retarding force of 3 700 N on the elevator.
- Calculate the:
- 2.3.1 Resultant force on the falling elevator (3)
- 2.3.2 Acceleration of the elevator while falling downwards (3)

2.4 An apple falls freely from a tree.



- 2.4.1 State Newton's Third Law in words. (2)
- 2.4.2 Write down the action-reaction forces when the apple falls. (2)
- [25]**



**QUESTION 3 (Start on a new page.)**

The diagram below shows two rugby players, **A** and **B**, running towards each other in a rugby match.

Player **A** with a mass of 100 kg is running at a speed of  $5 \text{ m}\cdot\text{s}^{-1}$  to the right and player **B** with a mass of 75 kg is running at a speed of  $4 \text{ m}\cdot\text{s}^{-1}$  to the left, as shown below. Ignore the effects of ALL forms of friction.

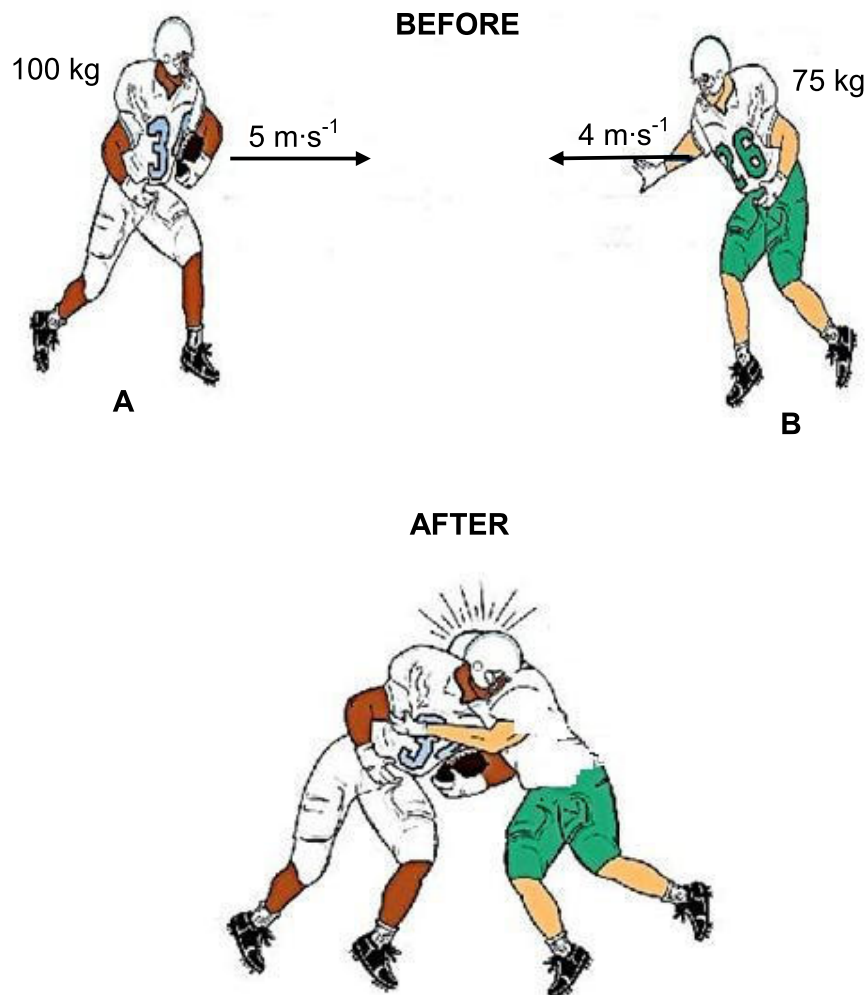

- 3.1 Define the term *momentum* in words. (2)
- 3.2 After making contact with each other, the two players move together.
- 3.2.1 Calculate the velocity of the players after making contact with each other. (4)
- 3.2.2 Name and state the physics law or principle you have applied in the calculation of your answer to QUESTION 3.2.1. (3)

- 3.3 Graph **A** below shows the net force versus contact time for a hard squash ball that rebounds off a brick wall. Study the graph carefully and then answer the questions that follow.

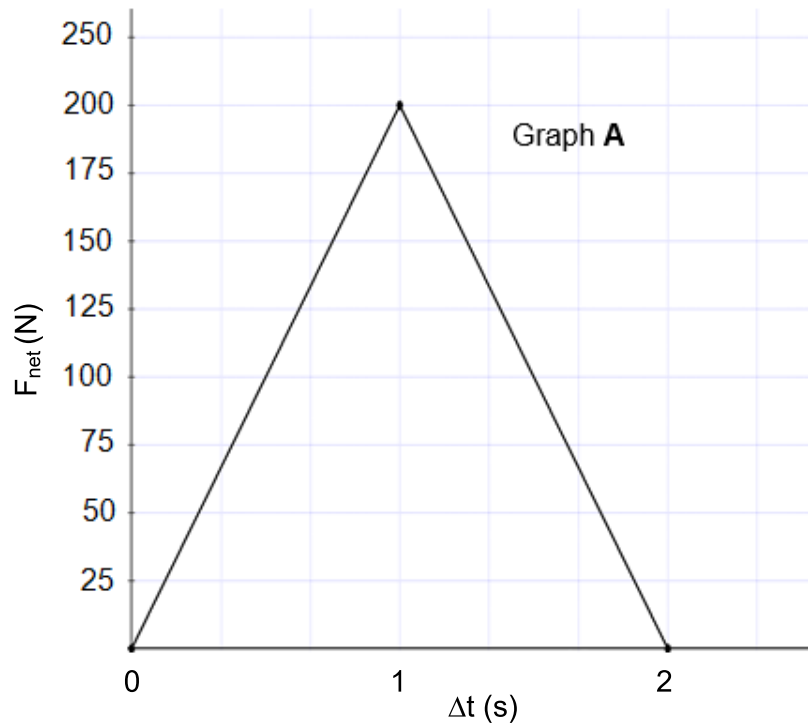

- 3.3.1 State Newton's Second Law of Motion in words, in terms of momentum. (2)
- 3.3.2 Calculate the area under graph **A**. (3)
- 3.3.3 Write down the name of the physical quantity that is represented by the area under the net force versus time graph. (1)
- 3.3.4 A softer squash ball of the same mass is now used and when it hits the brick wall, it experiences the same change in momentum as the hard squash ball.
- In your ANSWER BOOK, redraw graph **A** and on the same set of axes, draw an unscaled sketch graph of the net force versus time for the softer squash ball. Label it graph **B**. (3)
- 3.4 Write down TWO design features in modern cars that apply the principle of momentum and impulse to reduce the extent of injuries to passengers during a collision. (2)
- 3.5 Explain how any ONE of the design features in QUESTION 3.4 can reduce the extent of injuries. In your explanation, refer to TIME and NET FORCE or FORCE OF IMPACT. (2)

**[22]**

**QUESTION 4 (Start on a new page.)**

A crane is lifting an object of mass 600 kg from point **A** to point **B** at a CONSTANT SPEED to a vertical height of 25 m in two minutes, as shown in the diagram below. Ignore the effects of air friction.

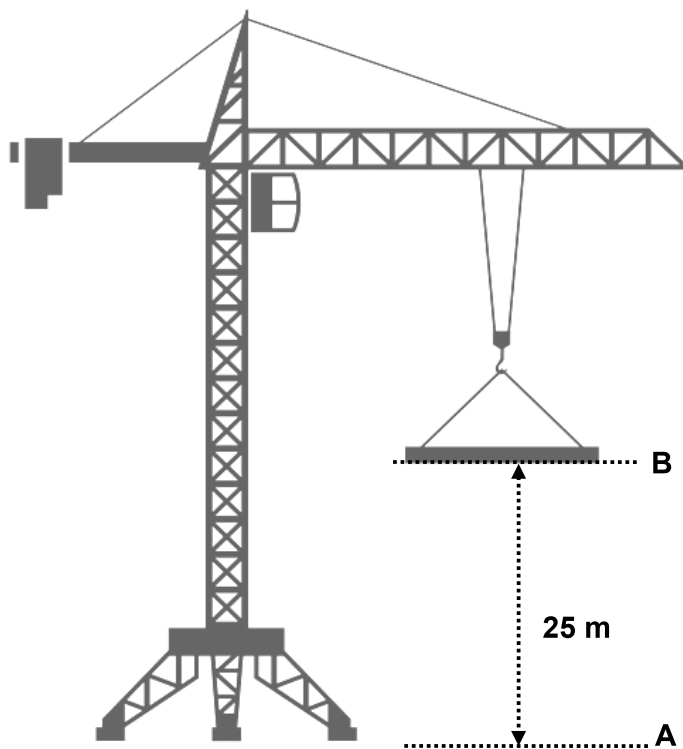

- 4.1 Calculate the:
- 4.1.1 Work done by the crane to move the object from **A** to **B** (3)
- 4.1.2 Power at which the crane operates (4)
- 4.2 Define the term *gravitational potential energy* in words. (2)
- 4.3 A construction worker stands on a scaffold and accidentally drops a brick of mass 3 kg. The brick hits the ground with a speed of  $7 \text{ m}\cdot\text{s}^{-1}$ . Ignore the effects of air friction.
- Calculate the:
- 4.3.1 Kinetic energy of the brick just before it hits the ground (3)
- 4.3.2 Height from which the brick was dropped (4)
- [16]**

**QUESTION 5 (Start on a new page.)**

A force,  $F_1$ , of 200 N is applied on a small piston of a hydraulic system with a diameter of  $5,046 \times 10^{-2}$  m. The area of a large piston,  $F_2$ , is  $5,25 \text{ m}^2$ , as shown in the diagram below.

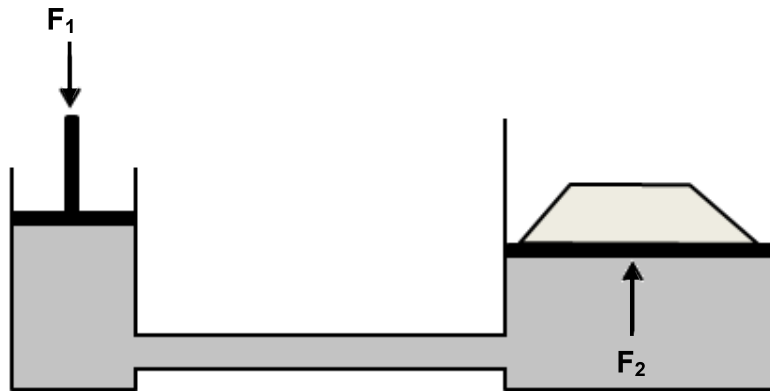

- 5.1 State Pascal's law in words. (2)
- 5.2 Calculate the force,  $F_2$ , on the large piston. (5)
- 5.3 The distance between the two pistons is decreased by using a shorter pipe.  
How will it affect the answer to QUESTION 5.2? Write only INCREASE, DECREASE or REMAIN THE SAME. (1)
- 5.4 Write down TWO applications of hydraulic systems. (2)
- 5.5 The diagram below shows a steel rod of length 1 m and a diameter of 0,02 m. A force,  $F$ , stretches the rod and produces a strain of  $0,16 \times 10^{-2}$ . Young's modulus of steel is  $2 \times 10^{11}$  Pa.

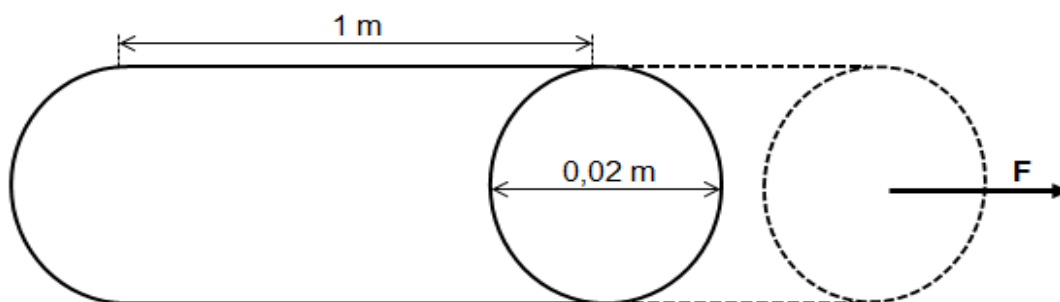

Calculate the:

- 5.5.1 Stress in the rod (3)
- 5.5.2 Force,  $F$ , applied on the rod (4)
- [17]**

**QUESTION 6 (Start on a new page.)**

- 6.1 A light ray strikes a reflective plane surface at an angle of  $58^\circ$  with the surface.

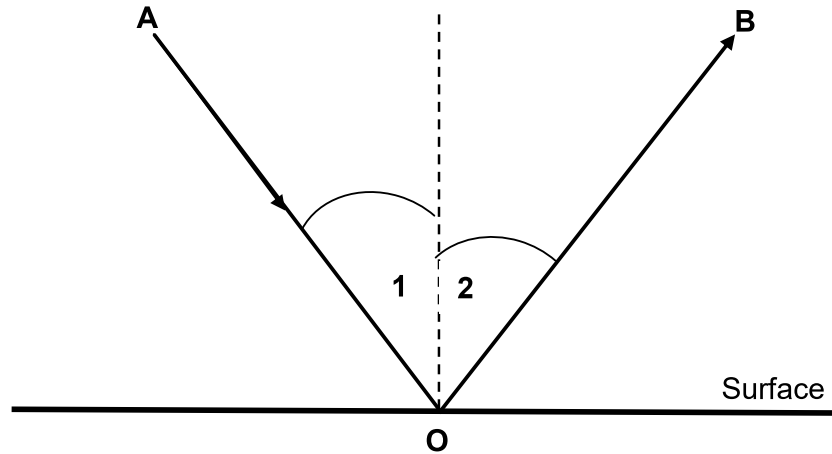

- 6.1.1 Define the term *reflection*. (2)
- Label the following:
- 6.1.2 Light ray **OB** (1)
- 6.1.3 Angle **1** (1)
- 6.1.4 Angle **2** (1)
- 6.1.5 State the relationship between angle **1** and angle **2**. (2)
- 6.2 The diagram below shows the path of a ray of red light striking a glass prism. Study the diagram carefully and answer the questions that follow.

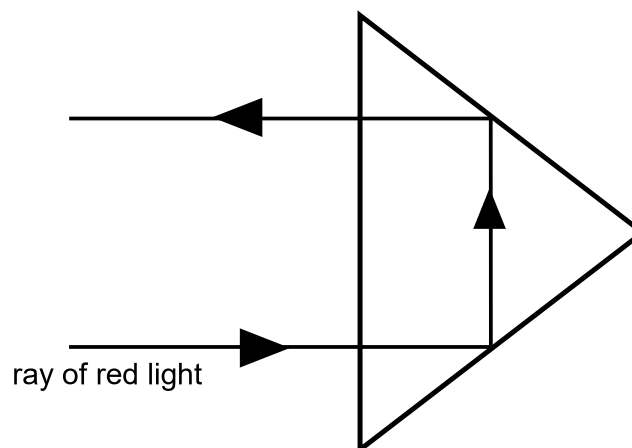

- 6.2.1 Name the phenomenon observed in the diagram. (1)
- 6.2.2 State TWO applications of the phenomenon in QUESTION 6.2.1. (2)
- 6.2.3 Write down TWO conditions for the phenomenon in QUESTION 6.2.1. (2)

- 6.3 The ray diagram below shows an image of an object placed between **F** and **2F** of a lens.

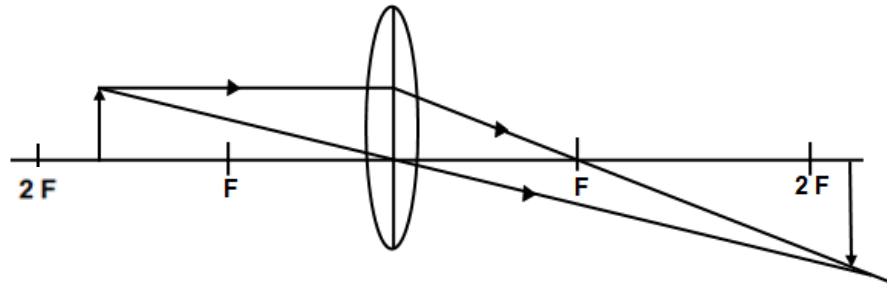

- 6.3.1 Name the type of lens used in the diagram. (1)
- 6.3.2 State TWO properties of the image formed by the lens in QUESTION 6.3.1. (2)
- 6.3.3 Give TWO uses of the lens in QUESTION 6.3.1. (2)
- 6.3.4 Give a reason why NO IMAGE is formed when the object is placed at **F**. (2)
- [19]**

**QUESTION 7 (Start on a new page.)**

A photon of electromagnetic radiation has a frequency of 2,4 GHz.

TYPE OF RADIATION	WAVELENGTH (m)
Radio wave	10 to $10^4$
Microwave	$10^{-3}$ to 0,3
Infrared	$8 \times 10^{-7}$ to $3 \times 10^{-5}$
Visible light	$4 \times 10^{-7}$ to $8 \times 10^{-7}$
Ultraviolet ray	$6 \times 10^{-10}$ to $4 \times 10^{-7}$
X-ray	$1 \times 10^{-10}$ to $3 \times 10^{-8}$
Gamma ray	$10^{-14}$ to $10^{-10}$

- 7.1 For this photon calculate the:
- 7.1.1 Energy (3)
- 7.1.2 Wavelength (3)
- 7.2 Use the table above to identify the type of radiation to which this photon belongs. (1)
- 7.3 Give ONE use of the radiation in QUESTION 7.2. (1)
- [8]**

**QUESTION 8 (Start on a new page.)**

A parallel plate capacitor has a capacitance of  $6 \times 10^{-12}$  F and a charge of  $0,3 \times 10^{-6}$  C on each one of the identical metal plates. The metal plates are 5 cm apart. The dielectric material for this capacitor is air.

- 8.1 Define a *capacitor*. (2)
- 8.2 State the relationship between the capacitance of a capacitor and the charge. (2)
- 8.3 Calculate the:
- 8.3.1 Potential difference between the metal plates (3)
- 8.3.2 Area of each metal plate (3)
- [10]**



**QUESTION 9 (Start on a new page.)**

The circuit diagram below was used to investigate the relationship between the current passing through resistor **R** and the potential difference across it at constant temperature.

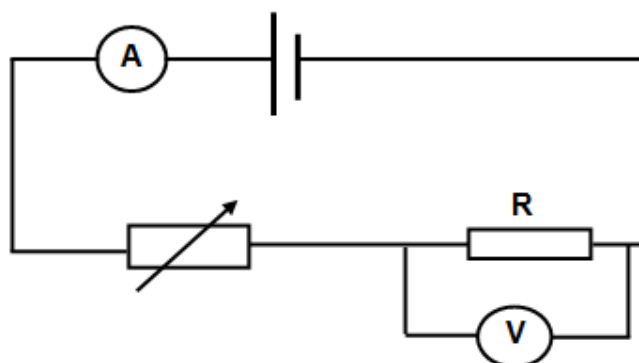

The results are shown in the graphs of current versus potential difference below.

**Graphs of current versus potential difference**

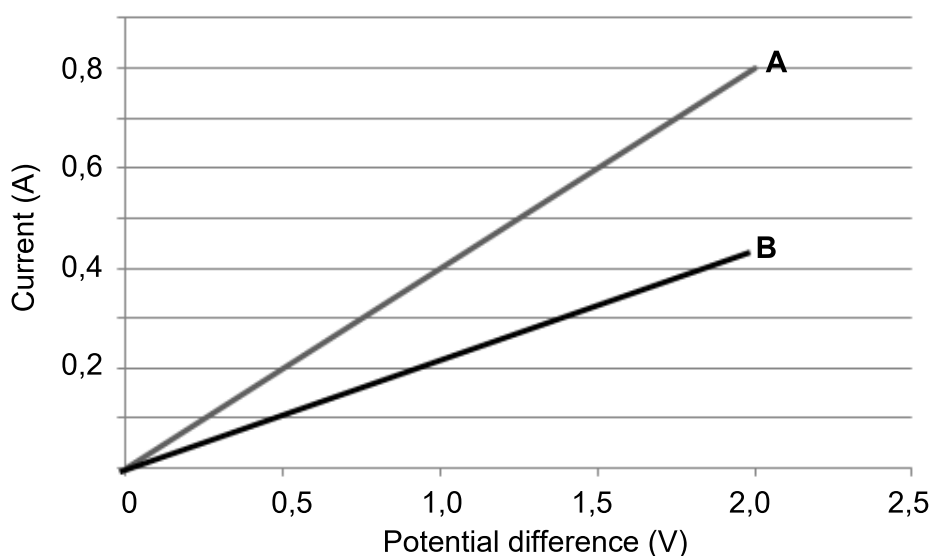

- 9.1 For this investigation, identify:
- 9.1.1 An independent variable (1)
- 9.1.2 A dependent variable (1)
- 9.2 Write down the conclusion that could be drawn from the shape of these graphs. (2)
- 9.3 Use the information in graph **A** to calculate the power dissipated by resistor **R** when the current is 0,6 A. (3)
- 9.4 How does the resistance of graph **A** compare to the resistance of graph **B**? Write down only HIGHER THAN, LOWER THAN or EQUAL TO. (1)
- 9.5 Explain the answer to QUESTION 9.4. (2)

**[10]**

**QUESTION 10 (Start on a new page.)**

The diagram below represents a simplified diagram of an electronic device connected to a light bulb.

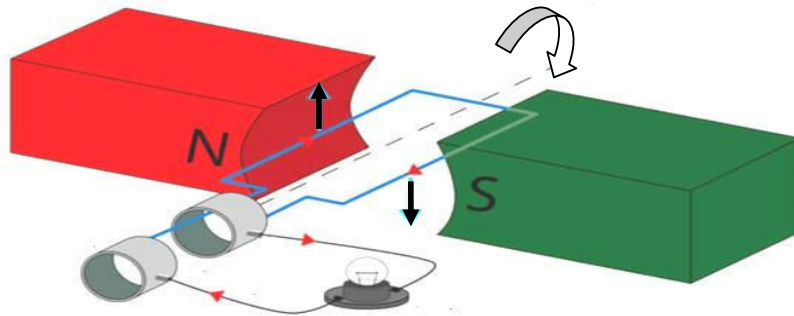

How would EACH of the changes below affect the brightness of the bulb? Write down only INCREASE, DECREASE or NO EFFECT.

- 10.1 A weaker magnet is used. (1)
- 10.2 A coil is rotated faster. (1)
- 10.3 The number of turns in the coil is increased. (1)
- [3]**

**TOTAL: 150**

**DATA FOR TECHNICAL SCIENCES GRADE 12  
PAPER 1**

**GEGEWENS VIR TEGNIESE WETENSKAPPE GRAAD 12  
VRAESTEL 1**

**TABLE 1: PHYSICAL CONSTANTS/TABEL 1: FISIIESE KONSTANTES**

NAME/NAAM	SYMBOL/SIMBOOL	VALUE/WAARDE
Acceleration due to gravity <i>Swaartekragversnelling</i>	g	9,8 m·s <sup>-2</sup>
Speed of light in a vacuum <i>Spoed van lig in 'n vakuum</i>	c	3,0 x 10 <sup>8</sup> m·s <sup>-1</sup>
Planck's constant <i>Planck se konstante</i>	h	6,63 x 10 <sup>-34</sup> J·s
Electron mass <i>Elektronmassa</i>	m <sub>e</sub>	9,11 x 10 <sup>-31</sup> kg
Permittivity of free space <i>Permatiwiteit van vrye spasie</i>	ε <sub>0</sub>	8,85 x 10 <sup>-12</sup> F·m <sup>-1</sup>

**TABLE 2: FORMULAE/TABEL 2: FORMULES**

**FORCE/KRAG**

$F_{\text{net}} = ma$	$p = mv$
$f_s^{\text{max}} = \mu_s N$	$f_k = \mu_k N$
$F_{\text{net}} \Delta t = \Delta p$ $\Delta p = mv_f - mv_i$	$F_g = mg$
$a = \frac{\Delta v}{\Delta t}$	$MA = \frac{L}{E} = \frac{e}{I}$

**WORK, ENERGY AND POWER/ARBEID, ENERIE EN DRYWING**

$W = F\Delta x \cos \theta$	$U = mgh$ or/of $E_p = mgh$
$K = \frac{1}{2} mv^2$ or/of $E_k = \frac{1}{2} mv^2$	$P = \frac{W}{\Delta t}$
$P_{\text{ave}} = Fv_{\text{ave}}$ / $P_{\text{gemid}} = Fv_{\text{gemid}}$	$M_E = E_k + E_p$

**ELASTICITY, VISCOSITY AND HYDRAULICS/ELASTISITEIT, VISKOSITEIT EN HIDROULIKA**

$\sigma = \frac{F}{A}$	$\varepsilon = \frac{\Delta l}{L}$
$\frac{\sigma}{\varepsilon} = K$	$\frac{F_1}{A_1} = \frac{F_2}{A_2}$
$P = \frac{F}{A}$	$P = \rho gh$

**ELECTROSTATICS/ELEKTROSTATIKA**

$C = \frac{Q}{V}$	$E = \frac{V}{d}$
$C = \frac{\varepsilon_0 A}{d}$ or/of $C = \frac{\kappa \varepsilon_0 A}{d}$	

**CURRENT ELECTRICITY/STROOMELEKTRISITEIT**

$R = \frac{V}{I}$	
$R_s = R_1 + R_2 + \dots$ $\frac{1}{R_p} = \frac{1}{R_1} + \frac{1}{R_2} + \dots$	$q = I \Delta t$
$W = VQ$ $W = VI \Delta t$ $W = I^2 R \Delta t$ $W = \frac{V^2 \Delta t}{R}$	$P = \frac{W}{\Delta t}$ $P = VI$ $P = I^2 R$ $P = \frac{V^2}{R}$

**ELECTROMAGNETISM/ELEKTROMAGNETISME**

$\phi = BA$	$\varepsilon = -N \frac{\Delta\phi}{\Delta t}$
$\frac{V_s}{V_p} = \frac{N_s}{N_p}$	

**WAVES, SOUND AND LIGHT/GOLWE, KLANK EN LIG**

$v = f \lambda$	$T = \frac{1}{f}$
$E = hf$ <i>or/of</i> $E = h \frac{c}{\lambda}$	