

SA's Leading Past Year

Exam Paper Portal

STUDY

You have Downloaded, yet Another Great Resource to assist you with your Studies 😊

Thank You for Supporting SA Exam Papers

Your Leading Past Year Exam Paper Resource Portal

Visit us @ www.saexampapers.co.za



SA EXAM
PAPERS



basic education

Department:
Basic Education
REPUBLIC OF SOUTH AFRICA

SENIOR CERTIFICATE EXAMINATIONS/ NATIONAL SENIOR CERTIFICATE EXAMINATIONS

TECHNICAL SCIENCES P1

2019

MARKS: 150

TIME: 3 hours

This question paper consists of 11 pages and 2 data sheets.

INSTRUCTIONS AND INFORMATION

1. Write your examination number and centre number in the appropriate spaces on the ANSWER BOOK.
2. This question paper consists of NINE questions. Answer ALL the questions in the ANSWER BOOK.
3. Start EACH question on a NEW page in the ANSWER BOOK.
4. Number the answers correctly according to the numbering system used in this question paper.
5. Leave ONE line between two subquestions, e.g. between QUESTION 2.1 and QUESTION 2.2.
6. You may use a non-programmable calculator.
7. You may use appropriate mathematical instruments.
8. Show ALL formulae and substitutions in ALL calculations.
9. Round off your FINAL numerical answers to a minimum of TWO decimal places.
10. Give brief motivations, discussions, etc. where required.
11. You are advised to use the attached DATA SHEETS.
12. Write neatly and legibly.

QUESTION 1: MULTIPLE-CHOICE QUESTIONS

Various options are provided as possible answers to the following questions. Choose the answer and write only the letter (A–D) next to the question numbers (1.1 to 1.10) in the ANSWER BOOK, e.g. 1.11 D.

- 1.1 The diagram below shows a stationary brick of mass 0,5 kg on a frictionless floor. This brick remains stationary when F_1 and F_2 are simultaneously applied.

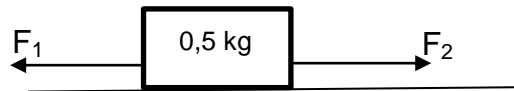

Which ONE of the following statements is CORRECT?

- A $F_1 = F_2$
 - B $F_1 = \frac{1}{2}F_2$
 - C $F_1 = 2F_2$
 - D $F_1 < F_2$ (2)
- 1.2 Newton's Third Law of Motion refers to action-reaction pairs of forces. Which ONE of the following statements is INCORRECT for action-reaction pairs?
- A They act along the same line.
 - B These forces simultaneously act on the same object.
 - C These forces simultaneously act on two different objects.
 - D These forces act in opposite directions. (2)
- 1.3 Two boxes, **R** and **Q**, of masses 30 kg and 60 kg respectively, rest on a frictionless horizontal surface. These boxes are then pulled with forces $F_R = 100\text{ N}$ and $F_Q = 100\text{ N}$ and they move to the direction of the applied forces.



How does the inertia of box **R** compare to the inertia of box **Q**?

- A Inertia of box **R** = Inertia of box **Q**
- B Inertia of box **R** > Inertia of box **Q**
- C Inertia of box **R** < Inertia of box **Q**
- D Inertia of box **R** = 2 x inertia of box **Q** (2)

- 1.4 The graph below represents the relationship between the work done on an object and the time taken.

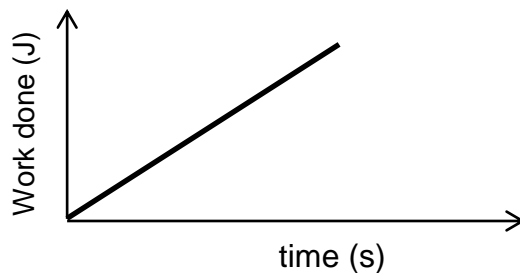

The gradient of the graph represents ...

- A power
 - B acceleration
 - C potential energy
 - D stress
- (2)

- 1.5 A crane is moving a pallet of bricks to the right while it applies an upward force of 15 925 N over a height of 1,8 m. The mass of the pallet of bricks is 1 625 kg, as shown in the diagram below.

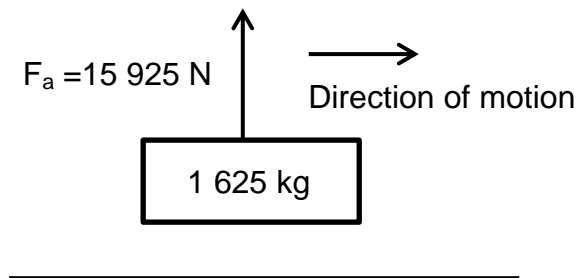

The amount of work done on the pallet by the applied force:

- A 28 665 J
 - B 1 625 J
 - C 0 J
 - D 15 925 J
- (2)

- 1.6 Which ONE of the following statements is CORRECT about a liquid with a low viscosity? It ...

- A has a high fluid friction.
 - B flows quickly.
 - C flows slowly.
 - D is a thicker fluid.
- (2)

- 1.7 Which ONE of the following statements is INCORRECT about semi-conductors?
- A Some semiconductors contain impurities.
 - B Semiconductors can conduct electricity.
 - C Glass is a semiconductor.
 - D Intrinsic semiconductors are pure semiconductors. (2)
- 1.8 A capacitor stores charge Q at potential difference V . What will happen to the magnitude of the charge if the potential difference is doubled and the capacitance is kept constant? The charge ...
- A will be Q^2 .
 - B remains Q .
 - C will be $\frac{1}{2}Q$.
 - D will be $2Q$. (2)
- 1.9 90 GPa is equal to ...
- A 9×10^{15} Pa.
 - B 90×10^6 Pa.
 - C 9×10^8 Pa.
 - D 90×10^9 Pa. (2)

1.10 Identify the type of motor represented in the diagram below:

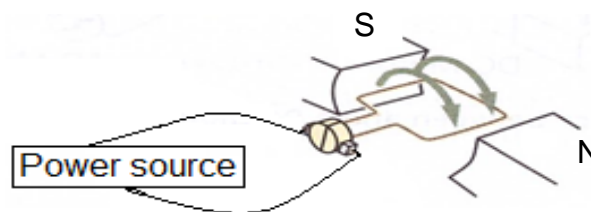

- A DC motor
 - B AC generator
 - C AC motor
 - D BC motor (2)
- [20]

QUESTION 2 (Start on a new page.)

2.1 The diagram below shows a box of 6 kg moving at constant velocity to the east while three forces, F_1 , F_2 and F_3 , are simultaneously exerted on it.

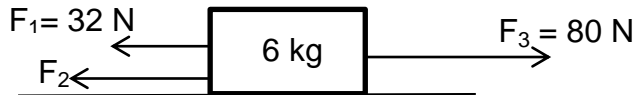

The surface is frictionless.

- 2.1.1 State Newton's First Law of Motion in words. (2)
- 2.1.2 What is the magnitude of the acceleration of the box? (1)
- 2.1.3 Calculate the magnitude of force F_2 if Newton's First Law is obeyed. (3)

2.2 A force (F_a) of 140 N is applied to push a block of mass 25 kg across a rough horizontal surface at an angle of 30° with the horizontal, as shown in the diagram below.

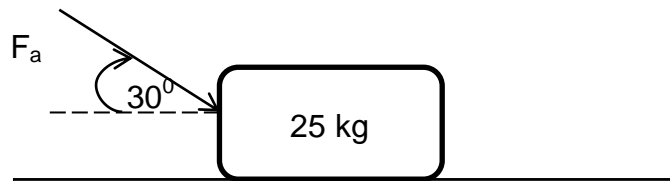

The coefficient of kinetic friction (μ_k) is 0,12.

- 2.2.1 Draw a labelled free-body diagram showing ALL the forces acting on the block. (4)
- 2.2.2 Calculate the magnitude of the kinetic frictional force experienced by the block. (4)
- 2.2.3 What will happen to the kinetic frictional force when the angle between the applied force and the horizontal is increased? Write only INCREASES, DECREASES or REMAINS THE SAME. (2)
- 2.2.4 Calculate the acceleration of the block. (4)
- 2.2.5 The same block of 25 kg now experiences a pulling force of 140 N, as shown in the diagram below. If everything else remains the same, how will the magnitude of the normal force be influenced? Write only INCREASE, DECREASE or REMAIN THE SAME.

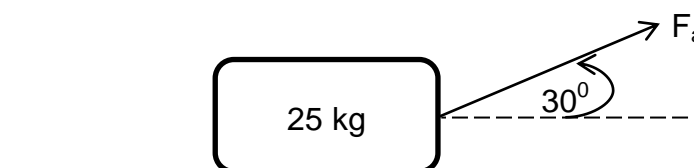

(2)
[22]

QUESTION 3 (Start on a new page.)

- 3.1 A baseball of mass 0,145 kg is thrown to a baseball player at a velocity of $49,17 \text{ m}\cdot\text{s}^{-1}$. The baseball player hits the ball back towards the bowler at a velocity of $31,39 \text{ m}\cdot\text{s}^{-1}$.



- 3.1.1 Define the term *impulse*. (2)
- 3.1.2 How will the impulse of the ball on the bat be affected when the velocity at which the ball returns towards the bowler is increased to a value greater than $31,39 \text{ m}\cdot\text{s}^{-1}$? Write only INCREASES, DECREASES or REMAINS CONSTANT. (2)
- 3.1.3 Will the net force exerted by the ball on the bat INCREASE or DECREASE when the time of contact between the ball and the bat increases? Give a reason for your answer. (Assume Δp remains constant.) (3)
- 3.1.4 Calculate the net force exerted by the bat on the ball when the contact time between the bat and the ball is 0,007 s. (4)
- 3.1.5 What is the magnitude and direction of the net force exerted by the ball on the bat? (2)
- 3.1.6 Name and state the law used to answer QUESTION 3.1.5. (3)
- 3.2 A car of mass 1 200 kg, travelling at a velocity of $30 \text{ m}\cdot\text{s}^{-1}$ to the east, crashes into the back of a truck of mass 9 500 kg moving in the same direction at $20 \text{ m}\cdot\text{s}^{-1}$. Ignore the effects of friction due to the road surface.

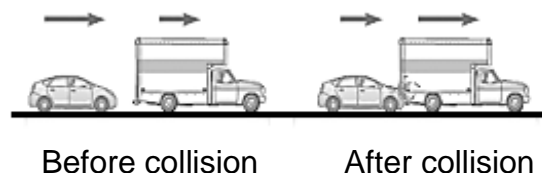

- 3.2.1 Is momentum a vector or scalar quantity? (2)
- 3.2.2 What is the condition required for a collision to be inelastic? (2)
- 3.2.3 Calculate the velocity of the truck-car combination after collision. (4)

[24]

QUESTION 4 (Start on a new page.)

4.1 An electrician working on an electric pole dropped his hammer of mass 0,56 kg at a height of 8 m above the ground. Assume that the system is isolated.

4.1.1 Define the term *kinetic energy*. (2)

4.1.2 State the principle of conservation of mechanical energy in words. (2)

4.1.3 Calculate the mechanical energy of the hammer at 8 m above the ground. (3)

4.1.4 Calculate the velocity of the hammer at a height of 3,5 m above the ground. (4)

4.1.5 Give the magnitude of the hammer's kinetic energy just before it hits the ground, without calculations. Give a reason for your answer. (3)

4.2 A man applies a force of 200 N to pull a crate full of bricks over a distance of 9 m. The total mass of the crate with its contents is 120 kg.

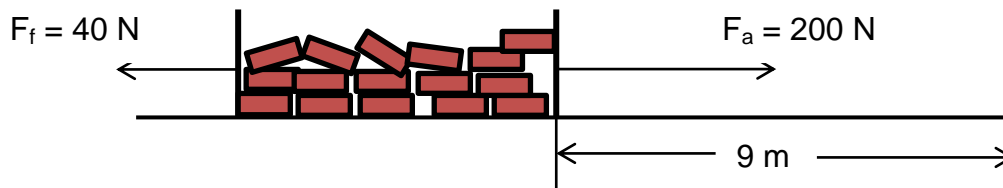

4.2.1 Define the term *work done*. (2)

4.2.2 Calculate the amount of work done by friction. (3)

4.2.3 What should be the size of the angle between the applied force and the direction of motion for the amount of work done on the crate and its contents to become zero (0 J)? (1)

4.2.4 Calculate the net work done on the crate and its contents. (4)

[24]

QUESTION 5 (Start on a new page.)

5.1 A 12 mm solid square bar is 250 mm long. A force of 3 000 N causes the bar to stretch to 252 mm long.

5.1.1 Define the term *stress*. (2)

5.1.2 Calculate the stress of the bar if the area is $1,44 \times 10^{-4} \text{ m}^2$. (3)

5.1.3 Determine the strain the bar experiences. (3)

5.1.4 What is the relationship between the modulus of elasticity and the flexibility of a substance? (2)

5.2 The diagram below shows a hydraulic system. A force of 300 N, F_1 , is exerted on **Piston 1** with a radius of 20 mm. **Piston 2** has an area of $2,83 \times 10^{-3} \text{ m}^2$.

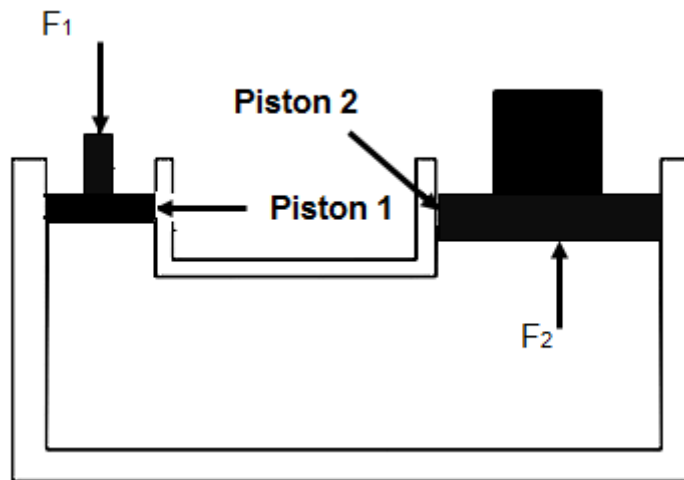

5.2.1 Calculate the radius of **Piston 2**. (3)

5.2.2 Calculate the upward force F_2 . (6)

5.2.3 State FOUR uses of hydraulic systems. (4)

[23]

QUESTION 6 (Start on a new page.)

- 6.1 Define the term *capacitance*. (2)
- 6.2 What is the relationship between the capacitance of a capacitor and the distance between the two plates? (2)
- 6.3 Study the drawing of a P-N junction diode below and label **X** and **Y** appropriately. (2)

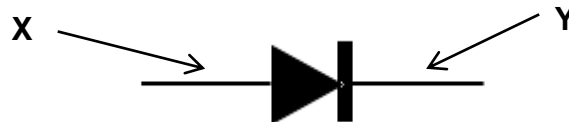

(2)
[6]

QUESTION 7 (Start on a new page.)

- 7.1 Define *power*. (2)
- 7.2 A circuit consists of a battery of FOUR cells connected in series, each with an emf of 3 V. The battery is then connected to two external resistors of 5 Ω and 2 Ω connected in parallel. The two resistors are connected in series with a third resistor of 2 Ω. (2)

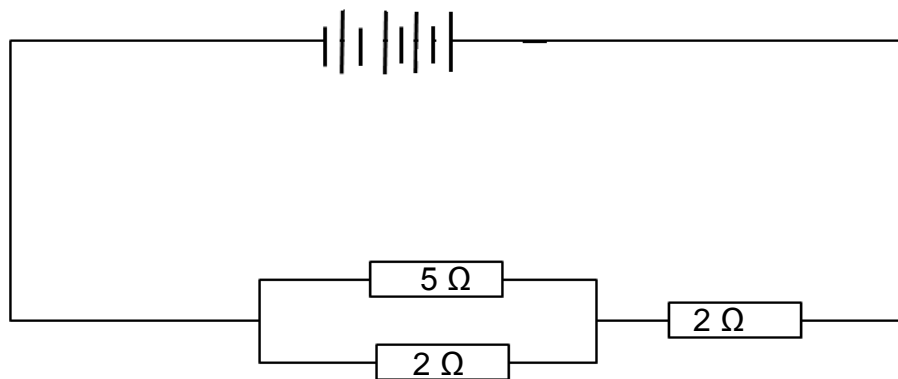

- 7.2.1 Calculate the total resistance of the circuit. (3)

The 5 Ω resistor is replaced with a 6 Ω resistor. How will this change influence the following? Write only INCREASES, DECREASES or REMAINS THE SAME.

- 7.2.2 Total resistance of the circuit (2)
- 7.2.3 Potential difference over the parallel combination (2)

- 7.3 Calculate the cost to run a washing machine of 230 V with a current of 20 A for ONE hour, if the price of electricity is R0,85 per kWh. (5)
[14]

QUESTION 8 (Start on a new page.)

- 8.1 State the right-hand rule to determine the direction of the magnetic field around a straight current-carrying conductor. (2)
- 8.2 Define *magnetic flux density*. (2)
- 8.3 A coil of wire is connected to a sensitive galvanometer. A bar magnet is positioned next to the coil, as shown in the diagram below.

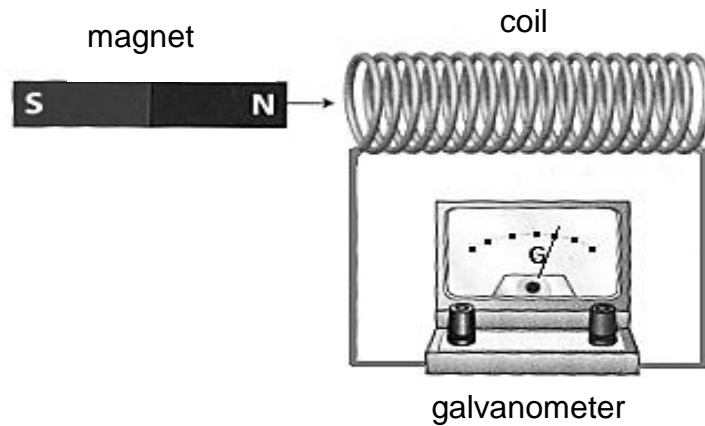

- 8.3.1 What will be observed on the galvanometer when the magnet is moved into the coil? (1)
 - 8.3.2 Name and state the law which is applied in this observation. (3)
 - 8.3.3 What happens when the speed of the movement of the magnet is increased? (2)
 - 8.4 State Lenz's law in words. (2)
- [12]**

QUESTION 9 (Start on a new page.)

- 9.1 The diagram below shows a transformer that has 1 200 turns on the primary coil and 60 turns on the secondary coil. The secondary voltage is 24 volts.

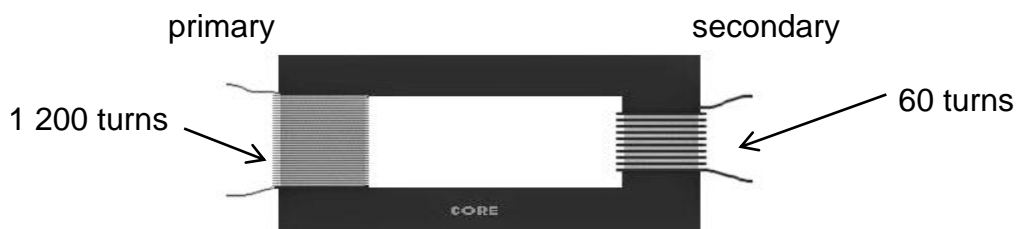

- 9.1.1 Is this a step-up transformer or a step-down transformer? Give a reason for your answer. (2)
 - 9.1.2 Calculate the primary voltage for this transformer. (3)
- [5]**

TOTAL: 150

**DATA FOR TECHNICAL SCIENCES GRADE 12
PAPER 1**

**GEGEWENS VIR TEGNIESE WETENSKAPPE GRAAD 12
VRAESTEL 1**

TABLE 1: PHYSICAL CONSTANTS/TABEL 1: FISIESE KONSTANTES

NAME/NAAM	SYMBOL/SIMBOOL	VALUE/WAARDE
Acceleration due to gravity <i>Swaartekragversnelling</i>	g	9,8 m·s ⁻²
Permittivity of free space <i>Permittiwiteit van vry ruimte</i>	ε _o	8,85 x 10 ⁻¹² F.m ⁻¹

TABLE 2: FORMULAE/TABEL 2: FORMULES

FORCE/KRAG

$F_{\text{net}} = ma$	$p = mv$
$f_s^{\text{max}} = \mu_s N$	$f_k = \mu_k N$
$F_{\text{net}} \Delta t = \Delta p$ $\Delta p = mv_f - mv_i$	$F_g = mg$

WORK, ENERGY AND POWER/ARBEID, ENERGIE EN DRYWING

$W = F \Delta x \cos \theta$	$U = mgh$ or/of $E_p = mgh$
$K = \frac{1}{2} mv^2$ or/of $E_k = \frac{1}{2} mv^2$	$P = \frac{W}{\Delta t}$
$P_{\text{ave}} = Fv_{\text{ave}}$ / $P_{\text{gemid}} = Fv_{\text{gemid}}$	$M_E = E_k + E_p$

**ELASTICITY, VISCOSITY AND HYDRAULICS/ELASTISITEIT, VISKOSITEIT EN
HIDROULIKA**

$\sigma = \frac{F}{A}$ / Stress = $\frac{\text{Force}}{\text{Area}}$ Druk = $\frac{\text{Krag}}{\text{Area}}$	$\epsilon = \frac{\Delta \ell}{L}$ / Strain = $\frac{\text{change in length}}{\text{original length}}$ Vervorming = $\frac{\text{verandering in lengte}}{\text{oorspronklike lengte}}$
$P = \rho gh$	$\frac{F_1}{A_1} = \frac{F_2}{A_2}$
$\frac{\sigma}{\epsilon} = K$ / modulus of elasticity = $\frac{\text{stress}}{\text{strain}}$ modulus van elastisiteit = $\frac{\text{spanning}}{\text{vervorming}}$	Pressure (P) = $\frac{\text{Force (F)}}{\text{Area}}$ Druk (P) = $\frac{\text{Krag (F)}}{\text{Area}}$

ELECTROSTATICS/ELEKTROSTATIKA

$C = \frac{Q}{V}$	$C = \frac{\epsilon_0 A}{d}$
-------------------	------------------------------

CURRENT ELECTRICITY/ELEKTRIESE STROOMBANE

$R = \frac{V}{I}$	
$R_s = R_1 + R_2 + \dots$ $\frac{1}{R_p} = \frac{1}{R_1} + \frac{1}{R_2} + \dots$ $R_p = \frac{R_1 \times R_2}{R_1 + R_2}$	$q = I \Delta t$
$W = VQ$ $W = VI \Delta t$ $W = I^2 R \Delta t$ $W = \frac{V^2 \Delta t}{R}$	$P = \frac{W}{\Delta t}$ $P = VI$ $P = I^2 R$ $P = \frac{V^2}{R}$

ELECTROMAGNETISM/ELEKTROMAGNETISME

$\phi = BA$	$\epsilon = -N \frac{\Delta \phi}{\Delta t}$
$\frac{V_s}{V_p} = \frac{N_s}{N_p}$	