

SA's Leading Past Year

Exam Paper Portal

STUDY

You have Downloaded, yet Another Great Resource to assist you with your Studies 😊

Thank You for Supporting SA Exam Papers

Your Leading Past Year Exam Paper Resource Portal

Visit us @ [www.saexampapers.co.za](http://www.saexampapers.co.za)



SA EXAM  
PAPERS



# basic education

Department:  
Basic Education  
**REPUBLIC OF SOUTH AFRICA**

## **NATIONAL SENIOR CERTIFICATE**

**GRADE 12**

**AGRICULTURAL TECHNOLOGY**

**NOVEMBER 2016**

**MARKS: 200**

**TIME: 3 hours**

**This question paper consists of 18 pages.**

**INSTRUCTIONS AND INFORMATION**

1. GENERAL INSTRUCTIONS AND INFORMATION
  - 1.1 This question paper consists of TWO sections, namely SECTION A and SECTION B.
  - 1.2 BOTH sections are COMPULSORY.
  - 1.3 Answer ALL the questions in the ANSWER BOOK.
  - 1.4 Number the answers correctly according to the numbering system used in this question paper.
  - 1.5 You may use a non-programmable calculator.
  - 1.6 Write neatly and legibly.
2. SECTION A: SHORT QUESTIONS
  - 2.1 This section consists of THREE questions.
  - 2.2 Follow the instructions when answering the questions.
3. SECTION B: STRUCTURED LONG QUESTIONS
  - 3.1 This section consists of FIVE questions.
  - 3.2 Start EACH question on a NEW page.

**SECTION A****QUESTION 1**

- 1.1 Various options are provided as possible answers to the following questions. Write down the question number (1.1.1–1.1.10), choose the answer and make a cross (X) over the letter (A–D) of your choice in the ANSWER BOOK.

EXAMPLE:

1.1.11  A  B  C  D

- 1.1.1 The plasma cutting machine cuts the metal with a/an ...
- A water jet.
  - B infra-red light beam.
  - C electric arc.
  - D mixture of burning gases.
- 1.1.2 The best gas mixture for cutting thick steel with a plasma cutting machine is ... because of its high cutting ability.
- A argon and hydrogen
  - B oxygen and acetylene
  - C propane and hydrogen
  - D helium and oxygen
- 1.1.3 Oxyacetylene cannot be used to cut ...
- A mild steel.
  - B cast iron.
  - C stainless steel.
  - D bronze.
- 1.1.4 ... does not cause undercutting when doing MIG welding.
- A Welding speed that is too fast
  - B Welding current that is too high
  - C A root gap that is too small
  - D Poor welding technique
- 1.1.5 If you see black smoke emitting from the exhaust pipe of a compression ignition engine, it indicates a/an ...
- A worn valve-stem seal.
  - B rich air fuel mixture.
  - C worn injector tip.
  - D incorrect sparkplug.

- 1.1.6 ... of the tractor weight should remain on the front wheels to prevent steering problems when lifting bales with the three-point mechanism.
- A 10%
  - B 30%
  - C 50%
  - D 80%
- 1.1.7 Which ONE of the following actions may harm a person working with compressed air?
- A Inflating a truck tyre inside a steel cage
  - B Blowing dust from your ears
  - C Spray-painting
  - D Using compressed oxygen as a substitute gas for plasma cutting
- 1.1.8 Global positioning systems (GPS) use at least three ... to determine a precise location anywhere on Earth.
- A cellphone towers
  - B area beacons
  - C radio-wave towers
  - D satellites
- 1.1.9 The function of variable-rate technology (VRT) is to ...
- A manage the gear ratio of a combine harvester.
  - B limit the speed of a baling machine.
  - C optimise the temperature of a tractor engine.
  - D manage the application rate of a pesticide sprayer.
- 1.1.10 A work angle deviation of more than ... may seriously damage a power take-off (PTO) system.
- A 37,5°
  - B 30°
  - C 27,5°
  - D 20°
- (10 x 2) (20)

1.2 Change the UNDERLINED word(s) in each of the following statements to make the statements TRUE. Write only the answer next to the question number (1.2.1–1.2.5) in the ANSWER BOOK, for example 1.2.6 Tractor.

1.2.1 Viruses, dust and moulds are classified as examples of chemical hazards.

1.2.2 The end of a hydraulic cylinder containing the shaft is weaker than the other end because of the volume that is subjected to the oil pressure.

1.2.3 When transporting heavy loads with a truck, the driver must change the tyre pressure when approaching a steep downhill area.

1.2.4 A barometer can be used to determine evaporation loss during irrigation scheduling.

1.2.5 The energy source that extracts heat from deep under the Earth's surface is called hydro energy. (5 x 2)

(10)

1.3 Choose a word/term from COLUMN B that matches the description in COLUMN A. Write only the letter (A–G) next to the question number (1.3.1–1.3.5) in the ANSWER BOOK, for example 1.3.6 H.

COLUMN A		COLUMN B	
1.3.1	Caused by a too large welding nozzle gap	A	spatter
1.3.2	Caused by rusty or primed plates when arc welding is done	B	methanol
1.3.3	Lowers exhaust emissions and increases the performance of a vehicle	C	levelling box
1.3.4	A device used to adjust the cross angle of an implement in relation to the movement of a tractor	D	top link
		E	slip clutch
1.3.5	A safety mechanism commonly used on the baling machine	F	ethanol
		G	porosity

(5 x 2)

(10)

**TOTAL SECTION A:****40**

**SECTION B****QUESTION 2: MATERIALS AND STRUCTURES**

**Start this question on a NEW page.**

- 2.1 Explain why a copper hammer should be used, and not a steel hammer, when hammer work is done where flammable vapours are present. (2)
- 2.2 Give THREE reasons for adding copper to metals to form an alloy. (3)
- 2.3 Name the process that is followed to soften tempered brass products for further working processes. (1)
- 2.4 Metal cans are used for the preservation of food. Answer the questions that follow.



- 2.4.1 Explain why these metal cans must be coated with a thin tin layer. (1)
- 2.4.2 Name THREE important properties of tin. (3)
- 2.5 Name THREE elements that are added to steel when manufacturing stainless steel. (3)
- 2.6 Suggest THREE aspects that should be considered when one needs to improve the cohesion properties of an adhesive. (3)
- 2.7 Name the substance that is added to resin to harden it when doing fibreglass repairs. (1)

2.8 Vesconite bushes are highly specialised thermoplastic parts made from internally lubricated polymers.



- 2.8.1 Why is Vesconite extremely suitable for marine application? (1)
- 2.8.2 Give THREE reasons why the machining of Vesconite holds no health risk for the person working with it. (3)
- 2.8.3 Discuss THREE reasons for choosing Vesconite over white metal when manufacturing bushes. (3)

2.9 Study the picture of an electric fence below and answer the questions that follow.

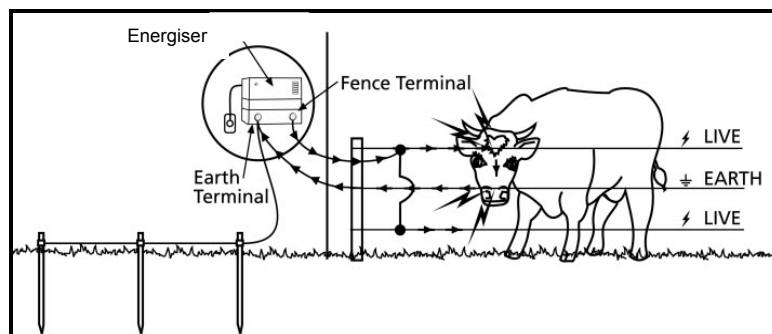

- 2.9.1 Name TWO preventative measures that may be followed to prevent lightning from damaging the energiser of an electric fence. (2)
- 2.9.2 Describe TWO methods that can be used to protect a permanent electric fence energiser system from theft. (2)
- 2.9.3 State THREE design requirements prescribed for the warning signs that are attached to electric fences. (3)
- 2.9.4 State TWO solutions to overcome the problem of reduced earthing efficiency in electric fences due to very dry soil. (2)
- 2.9.5 Discuss TWO rules or regulations that an electric fence, which is erected next to a public road, must adhere to. (2)

(2)  
**[35]**



**QUESTION 3: ENERGY**

**Start this question on a NEW page.**

3.1 Study the sectional view of a wind turbine below.

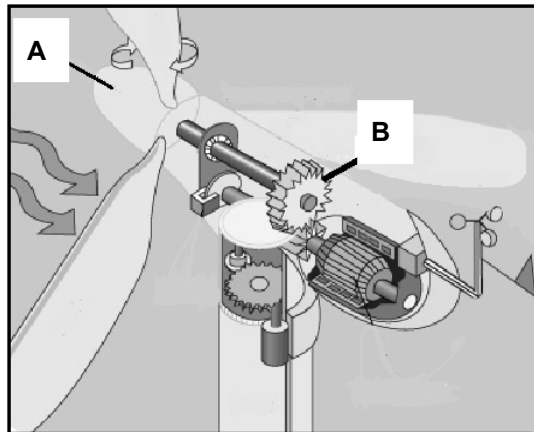

3.1.1 Identify parts **A** and **B** of the wind turbine above. (2)

3.1.2 State TWO problems associated with wind turbines used to generate electrical energy. (2)

3.1.3 Name and describe TWO devices installed on a wind turbine to ensure maximum efficiency of the turbine blades. (4)

3.2 A farmhouse in a rural area has running water, but no electricity.

Recommend TWO different systems that can be used in this situation to produce hot water. (2)

3.3 State THREE economic factors that influence the production of biofuel. (3)

3.4 Describe how electricity is generated in the hydro-electric plant below. (4)

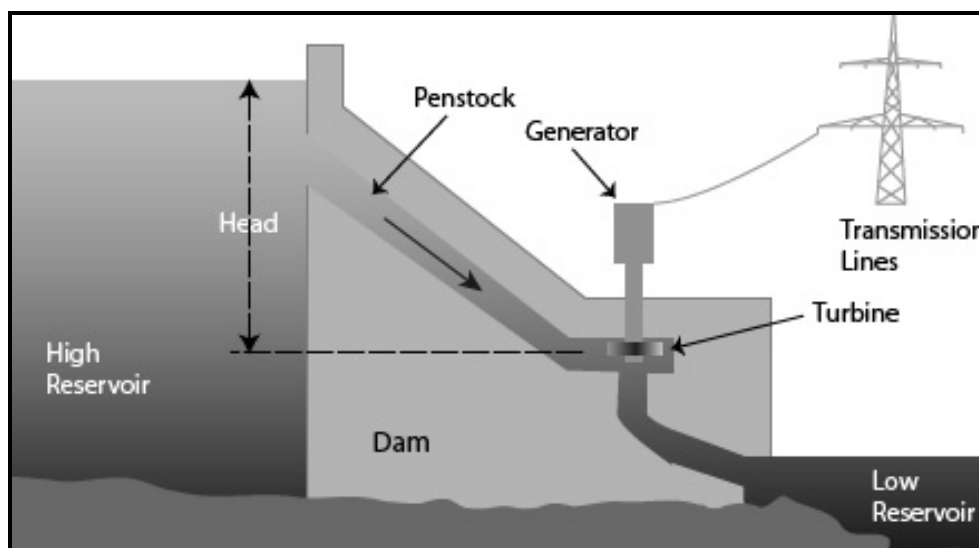

(4)

3.5 Using alternative energy sources relieves the pressure on the national electric energy system.

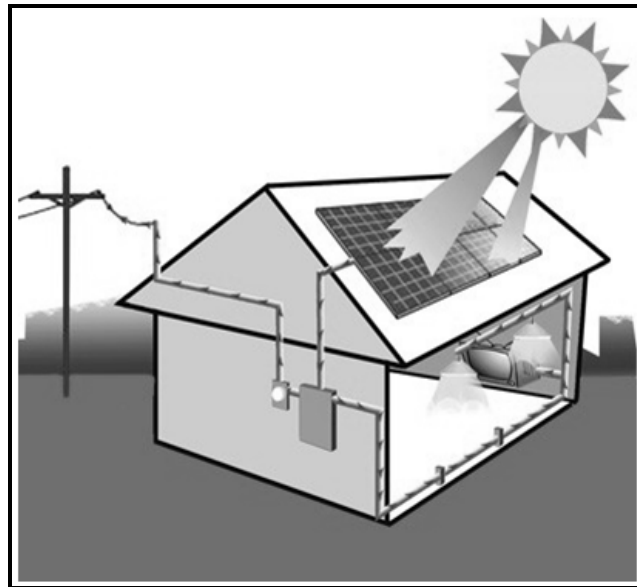

Name THREE applications of photovoltaic cells on a farm.

(3)  
[20]

**QUESTION 4: SKILLS AND CONSTRUCTION PROCESSES**

Start this question on a NEW page.

- 4.1 The picture below shows a plasma cutting machine. Answer the questions that follow.



- 4.1.1 Explain what will happen when water enters the torch of the plasma cutter nozzle. (2)
- 4.1.2 Give TWO reasons for using the welding helmet below when doing plasma cutting.



- 4.1.3 Identify the nozzle that is used for plasma cutting. Choose from pictures **A**, **B** or **C** below. (2)

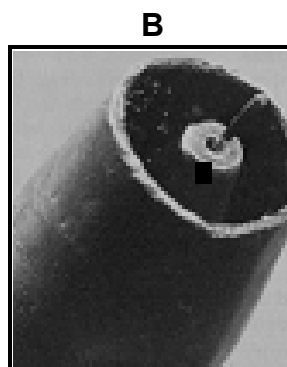
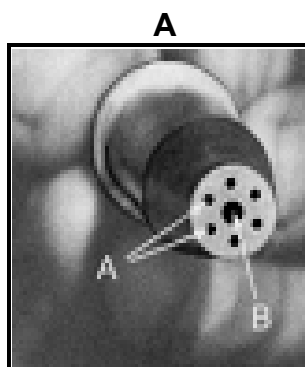

(1)

- 4.2 Name TWO kinds of wear that the bucket of the front-end loader below may be subjected to when working.



(2)

- 4.3 The sketch below shows distortion of a welded T-joint. Answer the questions that follow.

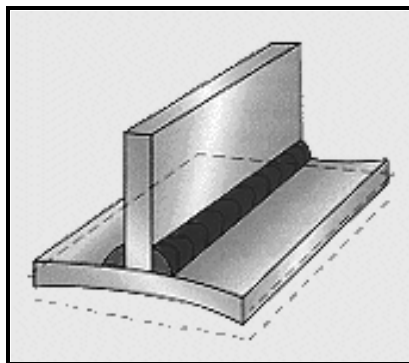

- 4.3.1 State THREE preventative measures to control distortion of the welded joints.

(3)

- 4.3.2 State THREE factors that influence the amount of distortion of a welded joint.

(3)

- 4.4 Draw TWO labelled sketches to indicate the difference between a *horizontal arc welding butt joint* and a *vertical up arc welding butt joint* when the metal is 6 mm thick.

(4)

- 4.5 Describe the procedure that must be followed to cut a 10 mm steel plate when using the oxyacetylene apparatus below.

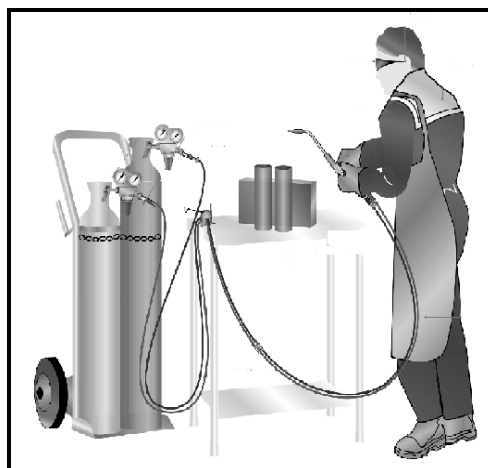

(5)

4.6 Metal inert-gas (MIG) welding and oxyacetylene welding use gas pressure gauges.

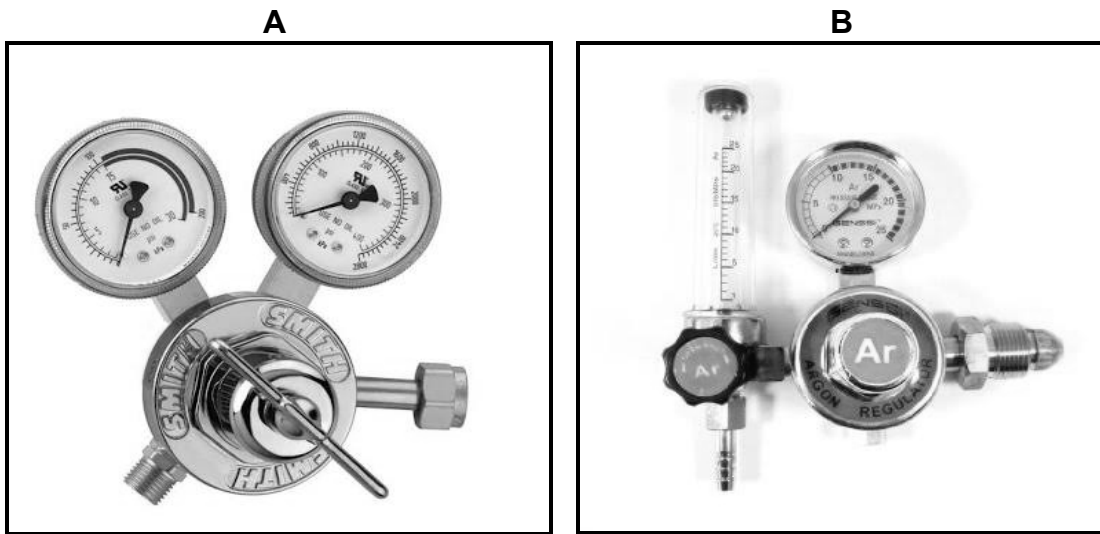

4.6.1 Identify which gauge (**A** or **B**) above is used for MIG welding. (1)

4.6.2 Describe the factors that must be considered when MIG welding is done on galvanised steel. (2)

4.6.3 State THREE disadvantages of MIG welding. (3)

4.7 A welder is requested to close the end of a steel irrigation pipe by using arc welding. The welder is able to weld 105 mm with one welding rod. The diameter of the pipe is 100 mm.

Calculate how many welding rods the welder needs to complete the job. Show ALL calculations.

Use the formula: Circumference of a circle =  $\pi \times \text{diameter}$  ( $\pi = 3,14$ ) (2)

4.8 Design and draw a neat freehand sketch of a two-station arc welding work table. Your design of the work table must include a safety aspect to protect fellow welders from the harmful rays of arc welding.

Label the different aspects of your drawing.

Marks will be allocated as follows:

- Design: 2 marks
- Dimensions: 1 mark
- Safety aspect: 1 mark
- Labels: 1 mark







(5)  
**[35]**

**QUESTION 5: TOOLS, IMPLEMENTS AND EQUIPMENT**

**Start this question on a NEW page.**

5.1 The purchase of a tractor is a huge financial expenditure for a farmer.

5.1.1 Choose the implement from COLUMN B that matches the tractor in COLUMN A. Write only the letter (A–C) next to the question number (5.1.1(a)–5.1.1(c)) in the ANSWER BOOK, for example 5.1.1(d) E.

COLUMN A	COLUMN B
<p>(a)</p> 	<p>A</p> 
<p>(b)</p> 	<p>B</p> 
<p>(c)</p> 	<p>C</p> 

(3 x 1) (3)

5.1.2 Tractor 5.1.1(c) will be a better choice than tractor 5.1.1(a) when one has to work in a vineyard. Give FOUR reasons to support this statement. (4)

5.1.3 Name FOUR technologically advanced devices that tractor 5.1.1(a) must be equipped with to make it highly efficient for precision spraying on a commercial farm. (4)

5.2 Name parts **A**, **B** and **C** in the transmission assembly below.

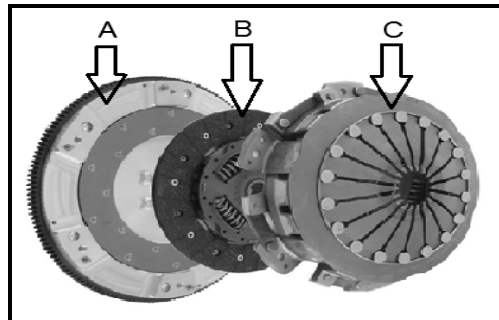

(3)

5.3 Two types of baling machines are shown below. Answer the questions that follow.

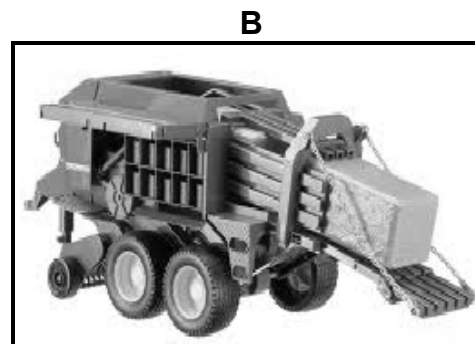
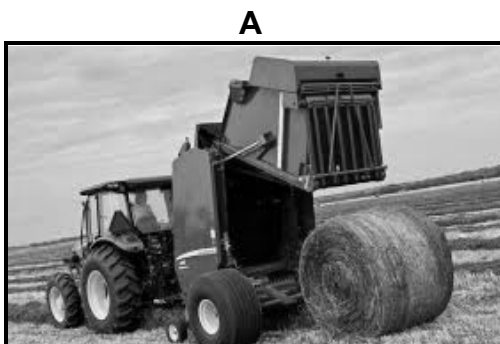

5.3.1 Identify the types of baling machines, **A** and **B**, shown above. (2)

5.3.2 Describe how the bale density may be changed in baling machine **B**. (2)

5.3.3 Give THREE reasons why a farmer would prefer baling machine **B** to baling machine **A** when baling hay. (3)

5.4 Describe the process of harvesting maize with a combine harvester.



(5)

5.5 Name THREE safety requirements when working with the hammer mill below.



(3)

5.6 Identify the TWO types of hydraulic cylinders shown below.

A



B

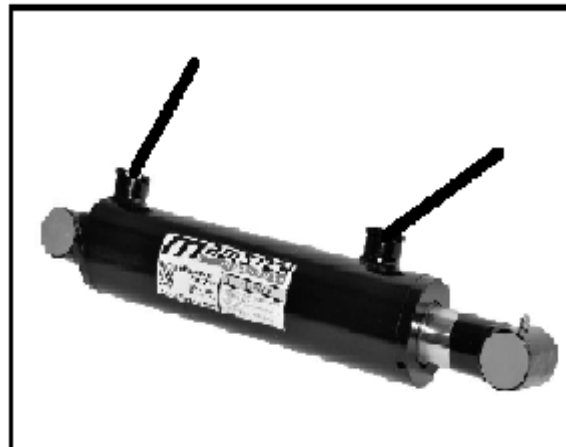

(2)

5.7 Explain why the drive shaft below must be equipped with a sliding joint.

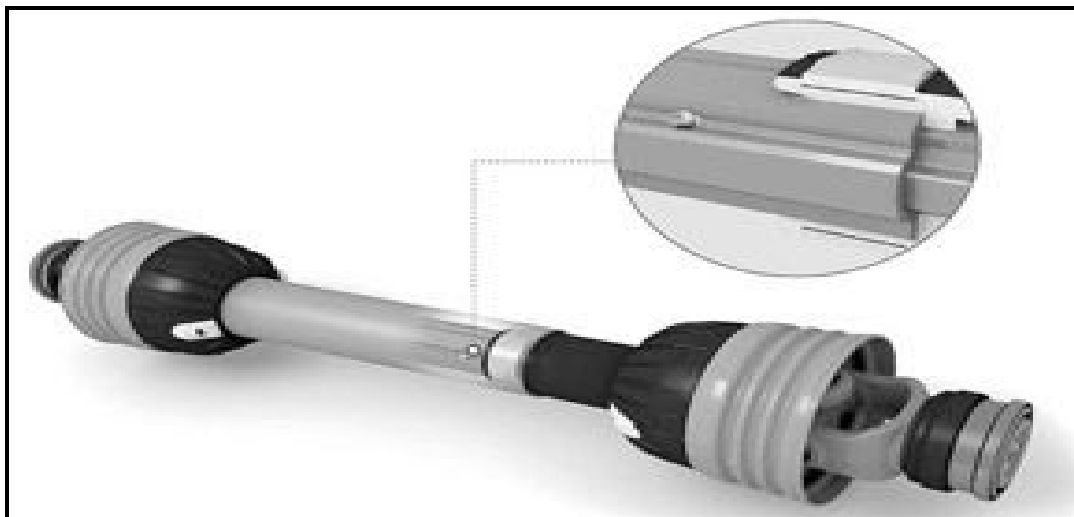

(2)



- 5.8 Name TWO running expenses of a tractor that a farmer must take into consideration when doing financial planning. (2)
- 5.9 A tractor needs adequate torque to plough hard soil with large implements. The torque of a tractor may be increased with the help of a final drive, as shown below.

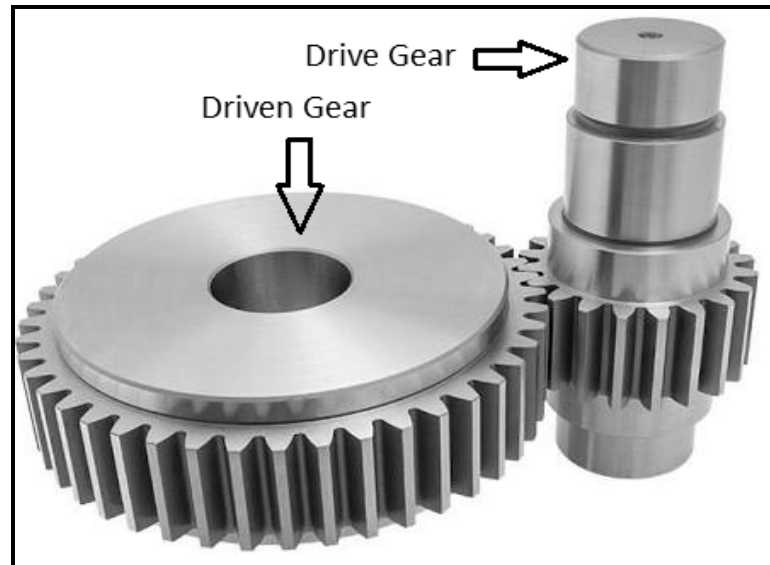

- 5.9.1 Determine the gear ratio of the final drive above if the drive gear has 22 teeth and the driven gear has 44 teeth. (1)
- 5.9.2 Explain why the final drive increases the torque. (2)
- 5.9.3 Calculate the speed of the driven gear if the speed of the drive gear is 200 r/min. Show ALL calculations. (2)
- [40]**

**QUESTION 6: WATER MANAGEMENT**

Start this question on a NEW page.

- 6.1 Name THREE problems associated with irrigation in South Africa. (3)
- 6.2 The photograph below shows a typical centre-pivot irrigation system.



- 6.2.1 Describe the construction of the centre-pivot irrigation system above. (3)
- 6.2.2 State the function of a smart controller in the working of a centre-pivot irrigation system. (2)
- 6.2.3 Name TWO sources from where the smart controller gets its data. (2)
- 6.2.4 State TWO disadvantages of the use of large centre-pivot irrigation systems. (2)
- 6.2.5 Give a reason why most centre-pivot irrigation systems have drop pipes with sprinkler heads that are placed a few centimetres above the crop. (1)
- 6.3 Briefly explain how a home fire suppression sprayer system works. (3)
- 6.4 The illustration below shows a sectional view of the internal construction of a septic tank. Answer the questions that follow.

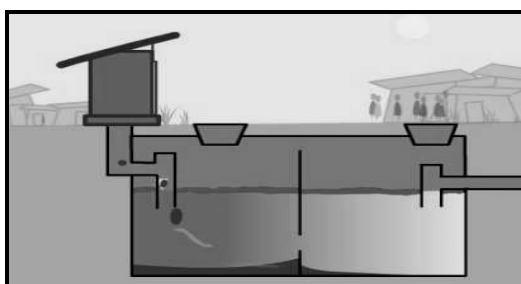

- 6.4.1 What is the name of the micro-organism that breaks down the raw sewerage in a septic tank? (1)
- 6.4.2 Explain why the inlet pipe of a septic tank ends in a T-fitting or baffle. (1)
- 6.4.3 Discuss THREE aspects to keep in mind with the maintenance of a septic tank. (3)

6.5 Briefly explain the construction of a French drain system. (1)

6.6 The photograph below shows a water purification system that is used to clean the water of a whole house. Answer the questions that follow.



6.6.1 Describe the working of the water purification system above. (3)

6.6.2 Calculate the time that it will take to fill a tank with water if the capacity of the water purification system is 50 litres per minute and the capacity of the tank is 10 000 litres. Show ALL calculations. (3)

6.7 Describe how data integration through a geographical information system (GIS) works on a combine harvester. (2)  
[30]

**TOTAL SECTION B: 160**  
**GRAND TOTAL: 200**